

## FOREWORD

Thank you for your purchasing motorcycle.

This manual covers the main data, basic structure, and main procedures of operation, adjustment, maintenance and troubleshooting of motorcycle. It will help you familiarize yourself with all the necessary skills so that you will bring your vehicle into full, best play with minimized trouble for a long service life.

Products are always subject to further improvement, which will cause some difference between the vehicle and this manual, without further notice.

After vehicle goes 10,000 kilometers, the emissions still meets the EPA requirements.

# CONTENTS

I .Safe Drive.....	1	Adjustment of Throttle Cable.....	16
II .Main Data.....	3	Adjustment of Carburetor.....	16
III .Parts and Subassemblies.....	5	Check-up & Adjustment of Air Valve Gap .....	17
IV .OPERATION.....	9	Adjustment of Clutch.....	19
Ignition Switch.....	9	Brake Checking.....	19
Fuel Cock.....	9	Adjustment of Front Brake.....	20
Engine Starting.....	10	Adjustment of Rear Brake.....	21
Switches on Right Handlebar.....	11	Adjustment of Chain.....	21
Switches on Left Handlebar.....	12	Adjustment of Braking Light Switch.....	22
Gear Shifting.....	12	Battery checking.....	23
V.Check-ups,Adjustments and Maintenance.....	13	Replacement of Fuse.....	24
Machine Oil Checking.....	13	Vehicle Washing.....	24
Renewal of Machine oil.....	13	Maintenance in Non-use Time.....	25
Cleaning of Machine Oil Tank .....	14	Resumption of Service.....	26
Check-up of Spark Plug.....	14	Maintenance Routine Diagram.....	27
Check-up,Cleaning of Air Filter.....	15	VI.Electrical diagram.....	28

# I .SAFE DRIVE

## Rules for Safe Drive

Check must be conducted, before starting the engine, to prevent mishaps and damage to components.

Only the qualified person, who has passed the drive examination and to whom a drive license has been issued, is permitted to drive the vehicle but not anybody else without a drive license.

Full preoccupation is required during drive, paying attention to the following points to avoid any possible hurt to you by other motorized vehicles:

Do not drive too close to other vehicles;

Never contend for lane.

Strictly observing the local traffic rules.

As driving at overspeed is the cause of many accidents, do not drive at a speed the actual situation does not permit.

Turn on the turnlight when making a turn or changing the lane.

Particular care should be exercised at the level crossing of roads, entrance and exit of parking lot or on the automobile lane.

During drive, grasp the left handlebar by the left hand and the throttle twist grip by the right one, with feet on the footrests.

The luggage carrier is designed for carrying light goods, which should be securely fastened to prevent loose movement that may cause mishaps during drive.

## Protective Wear

1. Protective wear such as helmet with protective mask, dustproof glasses and gloves should be worn during drive for the sake of personal safety.

2. The passenger should wear high boots or long clothes to protect legs from hurt by the heated exhaust silencer during ride.

3. Loose clothes are not suitable for motorcycle drive or ride as they may get caught on the operating lever, kick lever, footrest or wheel, resulting in danger.

Modification of the vehicle

### *Caution:*

*Any unauthorized modification of the vehicle or replacement of the original parts can not ensure driving safety and is illicit. The user must observe the regulations of the traffic control authorities. We are not responsible for any vehicle with unauthorized modification.*

Loading of goods

### *Caution:*

*The design of the motorcycle requires distribution of the carried goods in certain extent of equilibrium and improper arrangement of goods will adversely affect the performance and stability of the vehicle. The manufacturer shall not take any responsibility due to the reason mentioned above.*

## II .MAIN DATA

Overall length	1785mm	Cylinder bore × stroke	39 × 41.4mm
Overall width	680mm	Compression ratio	8:1
Overall height	1020mm	Output,max.	0.74kW/8000r/min
Wheelbase	1200mm	Torque,max	3.2N · m/6000r/min
Dead weight	82kg	Idling speed	1500r/min
Max. load	227kg(including the driver)	Displacement of cylinder	49.4ml
Front wheel	2.25–17/175	Spark plug	A7IC
Rear wheel	2.50–17/250	Spark plug gap	0.6–0.7mm
Speed, Max	≥ 30km/h	Cap of air Valve	Intake valve: 0.03mm
Brake distance	≤ 7m(30km/h)		Exhaust valve: 0.05mm
Climbability	≥ 16°		

To Be Continued···

## MAIN DATA

Volume of lubricating oil	SAE 15W40	Fuse	10A
Capacity of gasoline tank	2.8L	Front light illuminator	12V-35W/35W
Transmission ratio		Taillight/Braking light	12V-5W/21W
1st gear	3.273	Betraying light	12V-5W
2nd gear	1.611	Turnlight	12V-10W × 4
Transmission ratio of sprocket	2.928	Neutral light	12V-3.4W
Primary transmission ratio	3.722	Turn indicator	12V-3.4W
Battery	12V4Ah	Meter light	12V-3.4W
Ignition means	C.D.I	High beam indicator	12V-3.4W

### III .PARTS&SUBASSEMBLIES

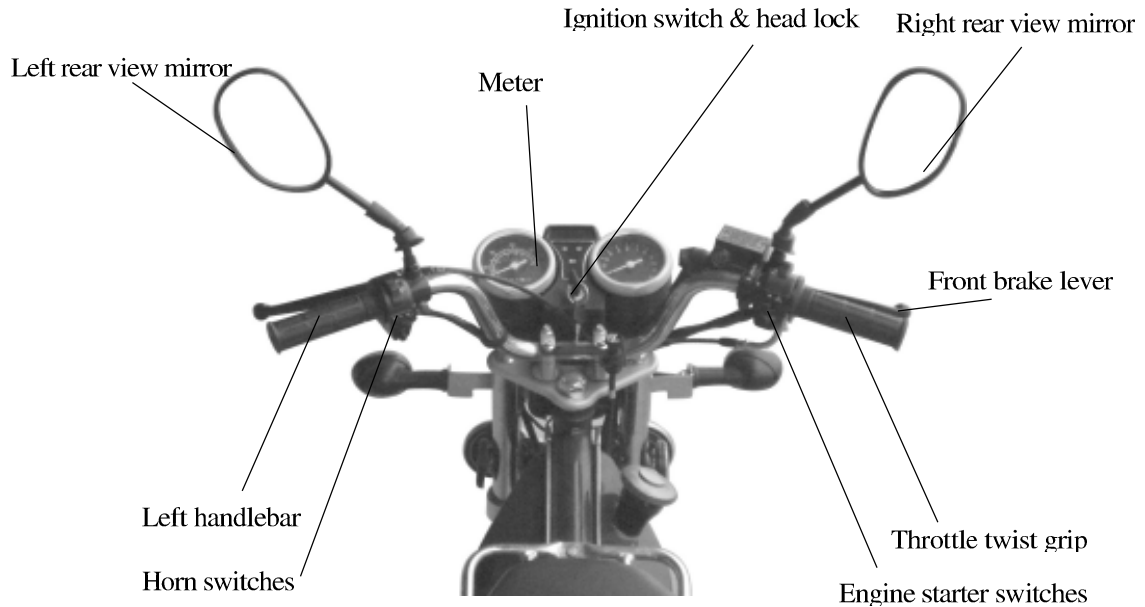

Ser.No	Name	Description
①	Speedometer	In km/h
②	Turn indicator	The left indicator is lit up when the turnlight is to the left and the right one lit up as the latter to the right.
③	Tachometer	It shows the speed(rpm) of the engine.
④	Gear position display	The gear position is displayed.
⑤	Neutral indicator	It is lit up when in the neutral position.

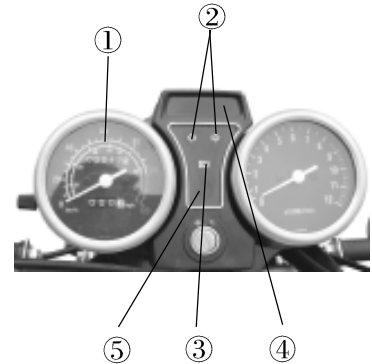



The ser. No. of frame [Vehicle Identification No.(VIN)] is on the right side and the brand on the front

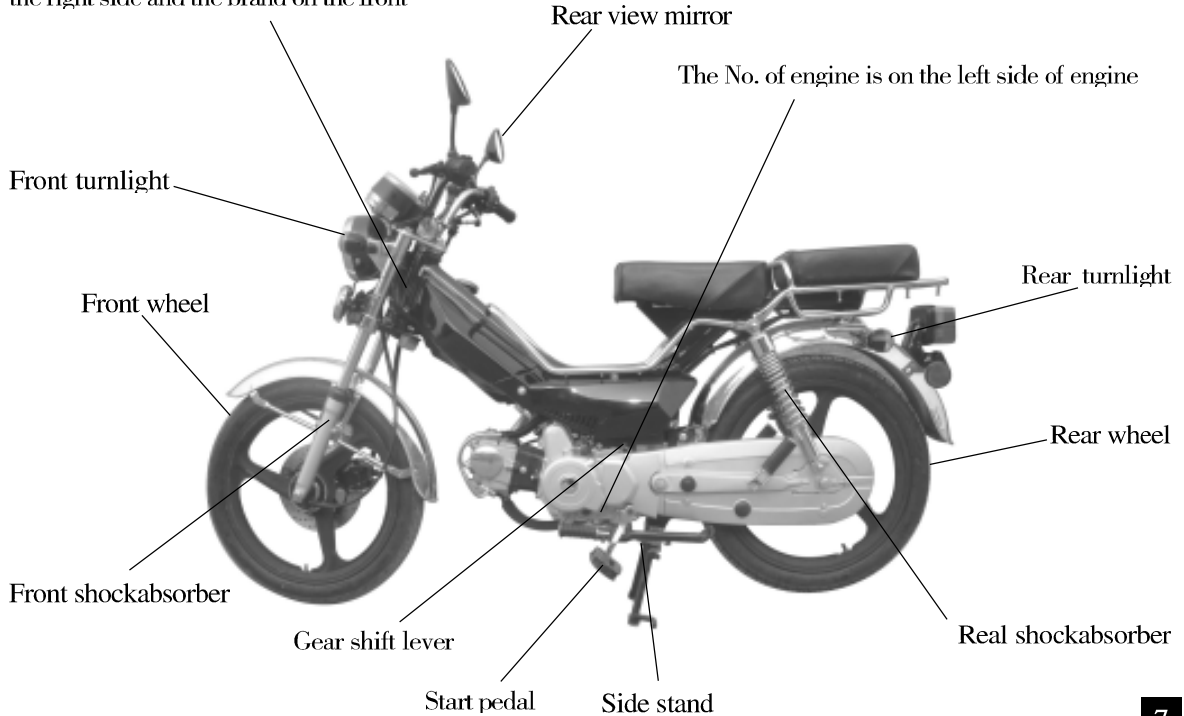

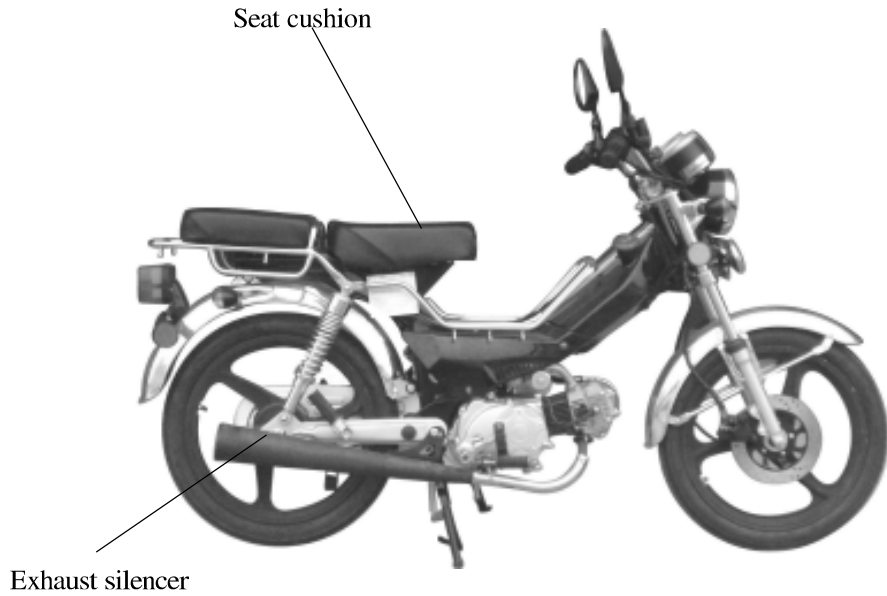

## IV. OPERATION

### Ignition Switch

#### ★ Ignition switch

Position	Function	Remarks
OFF	To stop the vehicle (switching off all circuits)	The key can be removed
ON	For starting or driving the vehicle (making all the main circuits)	The key can not be removed

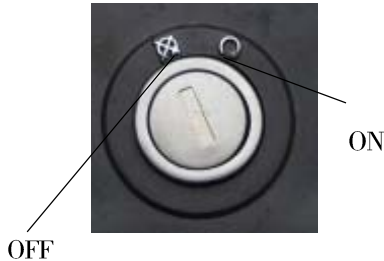

### Fuel Cock

#### ① Fuel filling

The capacity of the fuel tank is 2.8L in total including 0.8L of reserve. Leadless gasoline of No. 90 or above or low\_lead gasoline is required for the motorcycle. To fuel the vehicle, support it by the main stand, open the lock cover of the fuel tank and fill fuel through the opening, and then close the tank by the cover with the two on them in good alignment.

#### ② Operation of the fuel cock (the valve of fuel tank)

ON: With the handle of the fuel cock to "ON" position, the fuel circuit is through for fuel supply.

OFF: With the handle of the fuel cock to "OFF" position, the fuel circuit is cut off without

supply.

RES: With the handle of the fuel cock to RES position, the fuel is supplied from the reserve.

(Note: The reserved fuel can only be used when the normal supply is run out.) In this case, refueling should be carried out as soon as possible, for there is only some 0.8L of fuel reserve for use.

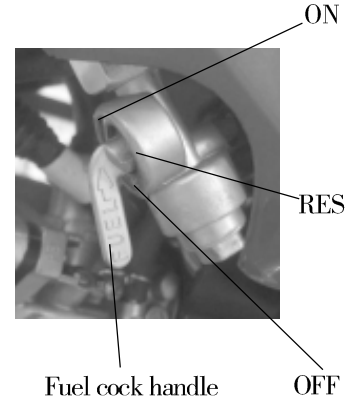

## Engine Starting

① Set the key of the ignition switch to “ON” position.

② Set the emergency stop switch to “” position.

③ Ascertain the neutral position, where it should be displayed.

④ Ascertain the amount of fuel in the tank.

⑤ Set the fuel cock handle to “ON” position.

★ To start a cold engine:

① Pull up the choke bar of the carburetor ( to close the choke ).

② Rotate the throttle twist grip by 1/8 to 1/4 turn.

③ Start the engine by the electric or the kick starting system.

④ Slightly turn the throttle twist grip to increase the speed of the engine so as to warm up the engine.

⑤ Turn the carburetor choke bar downward to "B", fully open the choke when the engine is sufficiently warmed up.

★ Manual starting way:

① Set the key of the ignition switch to “ON” position.

② Set the emergency stop switch to “” position.

③ Set the shift lever to low speed position and rotate start pedal, with a good coordination between the two operations to ensure a driving start.

★ **Caution:**

*The engine can only be started after the neutral position is ascertained. Otherwise accident will happen.*

*Unnecessary idle running(especially at a high speed)is harmful to the engine.*

★ Procedures of stopping engine:

① Release the throttle twist grip to slow down the engine.

② Turn to the neutral position.

③ Set the ignition switch key to “OFF” position.

④ Set the fuel cock(the fuel tank valve)handle to “OFF” position.

## Switches on Right Handlebar

### ① Headlight switch

The Headlight switch has three positions "☀", "P" and "•" (a white point).

"☀": When the switch is in this position, tail light and meter lights are all lit up.

"P": When the switch is in this position, the tail, betraying and meter lights are lit up.

"•": When it is in this position, the headlight tail, betraying and meter lights are all off.

The headlight and taillight will be lit up only after the vehicle is started.

### ② Electric start button (no such device for the vehicle of kick start mode only)

The electric start button is located below the headlight switch. The engine will be started by Pressing down this button.

### ③ Emergency stop switch

When starting the engine, set the emergency stop switch in "☒" position to directly stop the engine by cutting off the electric power.

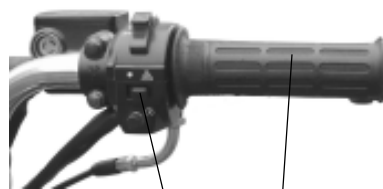

Throttle twist grip

Front illuminator switch

## Switches on Left Handlebar

① Light changing switch

☰ position, Headlight is in high beam.

☱ position, Headlight is in low beam.

② Turnlight switch

← Position, Left

→ Position, Right

③ Horn button

press this button to horn.

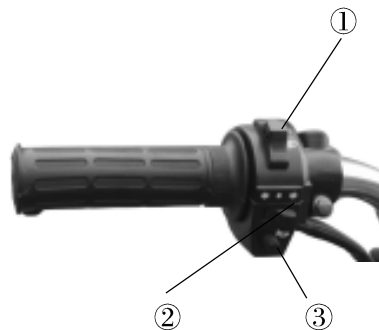

## Gear Shifting

Warm up the engine for normal running.

① When the engine is running, set the shift lever forward to let the gear to the low speed position. Gradually increase the speed of the engine to ensure a stable and safe running at low speed.

② When the engine is running, set the shift lever backward to let the gear to the high speed position. Gradually increase the speed of the engine to ensure a stable and safe running at high speed.

③ When the engine is idling, set the shift lever at middle position to let engine into a neutral state. Even gradually increasing the speed of the engine, the motorcycle still stay unmoved.

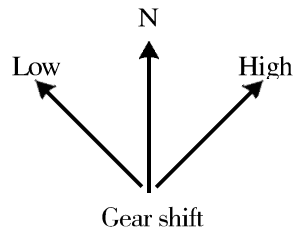

Shift lever





## Cleaning of Machine Oil Tank

① Drain off all the run-in machine oil from the oil tank.

② Dismount the related parts.

③ Wash clean all the related parts.

④ Fill in the required oil.

\*This job should not be done by any untrained persons but shall be done at an authorized service center.



Screw plug for oil draining



## Check-up of Spark Plug

① Remove the cap of spark plug and screw off the spark plug by the plug wrench.

② Clean the spark plug all around or replace it if it is corroded or there is too much deposit on it.

③ Regulate the gap of the spark plug to 0.6–0.7mm.

④ The spark plug of the designated type should be used.

The applicable type of spark plug as following:

A7TC

## Check-up,Cleaning of Air Filter

Take out the air filter and check if it is contaminated.

Dismounting:

Remove the left side cover screw of the filter,open the left cover and disassemble the air filter.

Cleaning:

Wash the filter in clean washing oil and wipe it dry with dry cloth.

Soak the filter element in clean machine oil,squeeze it dry and fit it back to position.

Recommended oil:15W/40QE

**Caution:**

*The air filter element for use must be intact or the engine will suck in dust and dirt,resulting a shorter service life of the engine.*

*Water should be prevented from entering into the filter in washing the vehicle.*

*The filter shall never be cleaned with gasoline or any other agent of a low ignition point.*



## Adjustment of Throttle Cable

Make sure that the adjusting nut of the throttle cable works normally.

Check to see if the throttle twist grip is with the required free operating movement.

The required free operating movement:2–6mm.

If the grip can not be so moved freely,turn the adjusting nut to ensure it.

*\*After adjustment,start the engine and check for the free operating movement again. Repeat the adjustment if necessary until it is as required.*

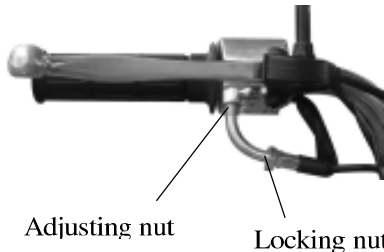

## Adjustment of Carburetor

**Caution:**

*The idling speed adjustment of the engine should be carried out with a hot engine.*

*Set the idling speed to the required value by the help of the idling speed adjusting screw with the vehicle standing on a flat ground.*

The required idling speed:1,500r/min.

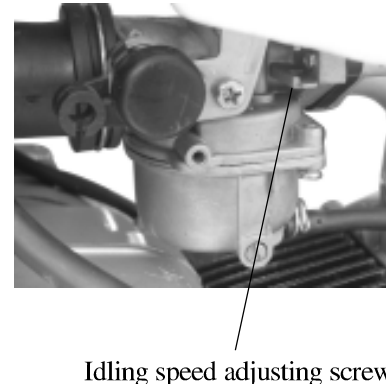

## Check-up & Adjustment of Air Valve Gap

Noise will stem from too big gap of the air valve. However if there is too small gap or even no gap at all, closing of the valve will be hindered, which will cause burn of the valve and output drop. Therefore, the air valve gap must be checked periodically.

The gap of the air valve should be inspected and adjusted with a cold engine by the following procedures:

① Remove the caps of the central hole and the top hole (the ignition timing observation hole) in the left crankcase cover.

② Remove the caps of the two air valves on the cylinder head.

③ Insert the "T" key into the central hole of the crankcase cover, jam it against the nut of the flying wheel and then turn the flying wheel clockwise until the engraved "T" mark on the flying wheel aligns with the engraved line on the top of the crankcase cover. Swing the rocking arm slightly. A loose rocking arm (which indicates the existence of clearance) shows that the piston is in the lower stop position of the compressing stroke. In this case, continuously turn the "T" key clockwise for 360 degrees until the alignment of those engraved marks, where the valve can be adjusted. Afterwards, check the valve gap by inserting a feeler in between the valve adjusting screw and the end of the valve.

The specified air valve gap: 0.03mm for the intake and 0.05mm for exhaust valves respectively.

④If the adjustment needed,loosen the locking nut of the valve,turn the adjusting nut till a slight resistance is felt on inserting the feeler.

At the end of the adjustment,tighten the "Locking nut" to prevent loosening and conduct another check to make sure that the valve gap is OK before all those dismantled caps are refitted on.

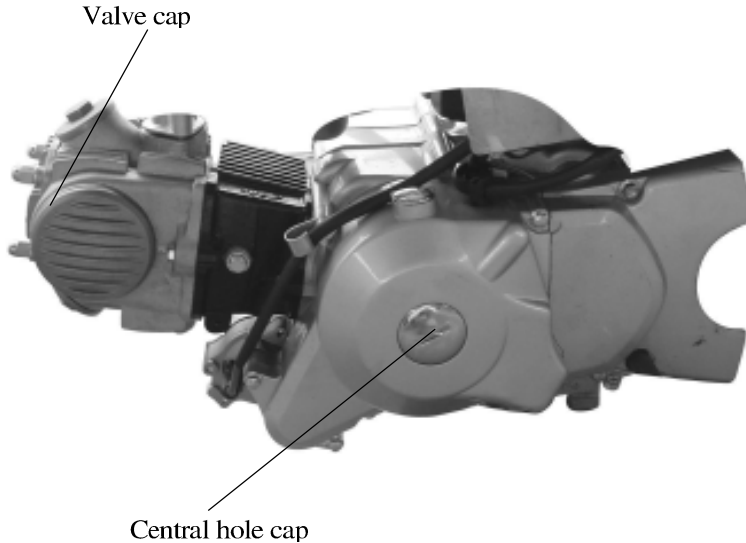

## Adjustment of Clutch

★ The clutch should be adjusted with the engine in stopped state.

There should be a free operating movement of 10–20mm at the end of the clutch lever as shown in the figure on the right side.

When adjustment is needed, loosen the locking nut on the clutch operating cable and set the clutch lever to the required range of free operating movement. In case of adjustment to be made to a great extent, turn the clutch adjusting screw stud on the right crankcase.

Starting the engine to ascertain whether the adjusted clutch works normally.

★ Readjustment has to be made if there is slipping of clutch or difficulty in the engagement of gears.

## Brake Checking

(1) Pull up the front and rear brakes respectively and check for wear of the brake shoes. If the mark "△" on the brake drum cover aligns with that "△" on the brake cam, it means that the brake shoes are already worn to the limit and have to be replaced.

(2) Replacement should be carried out at a designated service center and it is recommended that the parts made by our company are used therein 10–20mm.



## Adjustment of Front Brake

(1)The front brake lever has a free operating movement of 10–20mm as shown in the figure on the right side.

(2)If adjustment is needed,turn the adjusting nut near the lower side of the front hub,clockwise to reduce and counterclockwise to increase the free operating movement of the brake lever.

(3)After adjustment,the groove of the adjusting nut should be aligned with the pin of the brake arm.

### **Caution:**

*After adjustment,check the front braking system.The braking light should be lit up on time when the front brake is applied by gripping the brake lever.*

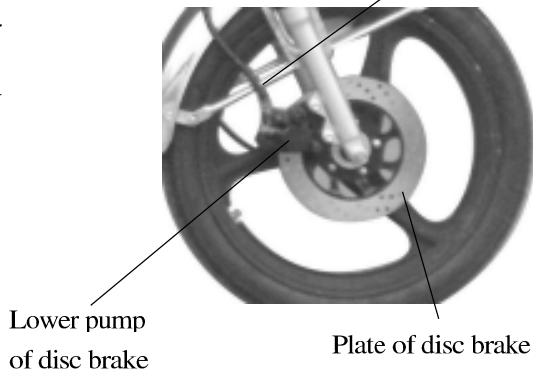
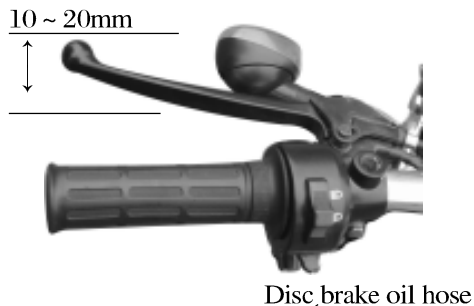

## Adjustment of Rear Brake

★ The vehicle should be supported by the main stand for check.

(1) The rear brake pedal has a free operating movement of 20–30mm as shown in the figure on the right side.

(2) To make adjustment, turn the rear brake adjusting nut clockwise to reduce and counterclockwise to increase the free operating movement of the brake pedal.

(3) After adjustment, the groove of the adjusting nut should be aligned with the pin of the brake arm.

### *Caution:*

*After regulation, check the rear braking system. The braking light should be turned on time when the rear brake is applied by stepping down the brake pedal.*

## Adjustment of Chain

★ Check the chain for wear, tension and lubrication.

(1) With the motorcycle supported by the main stand, turn the upper and lower portions of the chain by hand to check for its tension to see if the sag is within the specified range of 10–20mm.

(2) When regulation is needed, loosen the axle nut and locking nut of the rear wheel, then set the chain to the required tension by turning the adjusting nut.

(3) Apply a little grease to the chain.

### *Caution:*

*At the end of regulation, the marks on the chain adjuster should be in good coordination with the engraved line on the horizontal fork as position is concerned.*

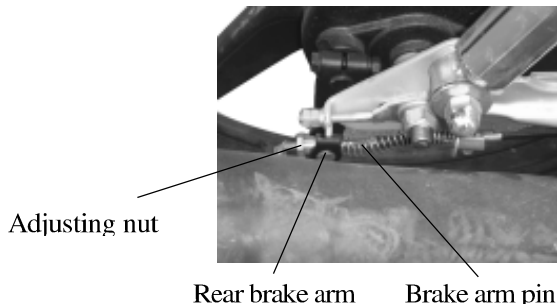



Chain adjuster(with graduations)

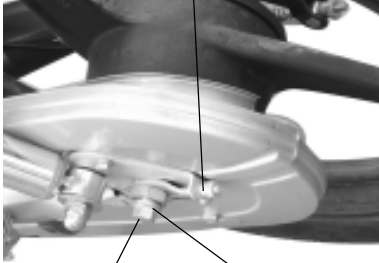

Rear wheel axle nut      Bear axle

Braking light switch      Adjusting nut

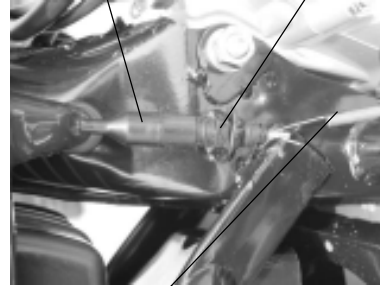

Braking light switch spring

## Adjustment of Braking Light Switch

★The braking light should be lit up on time as soon as the rear wheel is braked.If not,regulation shall be made by turning the adjusting nut.

★ With the braking light switch in "ON" position,the braking light should be lit up.If not ,check should be carried out to see whether the braking lamp,circuit and switch work normally,Make replacement if needed.

### *Caution:*

*For the adjustment of the braking light switch,the brake needs to be first checked to make sure that the free operating movement is ensured within the specified range.*

## Battery Checking

- ① Open the right side cover.
- ② Clean away dust and corrosive from the surface of the battery.
- ③ Set the vehicle in a vertical position to see whether the level of the battery electrolyte is between the upper and lower mark lines. If it is below the lower one, distilled water shall be added to the battery.
- ④ Seriously corroded conductor connectors of the battery shall be replaced.

### **Caution:**

*To dismantle battery, disconnect the negative(-) electrode before the positive(+) one, and vice versa in installation. Ensure against any contact of the positive(+) electrode with the vehicle body.*

*Never have the electrolyte level come over the upper mark line when adding distilled water. Otherwise overflow and corrosion*

*will occur.*

*The electrolyte contains sulfuric acid and will cause serious hurt to skin and eyes by contact. In case of contact with it, wash it off for 5 minutes and see a doctor immediately.*

*Foreign matter should be prevented from entering into the battery during dismantling and installation.*

*The breathing pipe must be kept unblocked.*

Negative(-)  
connector

Positive(+)  
connector

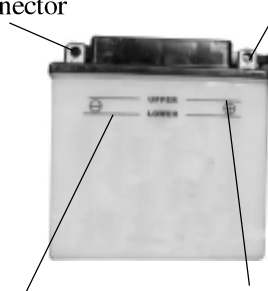

Lower electro-  
lyte level line

Upper electrolyte  
level line

## Replacement of Fuse

Set the ignition switch to "OFF" position. The specified fuse tube of 10A should be used for replacement.

Open the left side cover, remove the fuse holder on the side of the battery and replace the fuse tube.

If the new fuse tube is broken again as soon as it is fitted on, it means that there is some trouble with other electric parts.

### **Caution:**

*Do not use any fuse over 10A*

*Be sure not to wash the battery when washing the vehicle.*

## Vehicle Washing

Cleaning the vehicle regularly can slow down the color fading of its body make it easier to check if there is any damage and any oil leakage with it.

***Caution:***

***Washing the motorcycle with over-pressurized water may cause damage to some of its components. Therefore, do not jet over-pressurized water directly on to the following parts:***

- Wheel hub
- Exhaust pipe
- Fuel tank and lower portion of cushion
- Carburetor
- Head lock and ignition switch
- Meters

(1)After pre-wiping,the vehicle should be washed with clean water to remove dirty residues so as to prevent corrosion.Plastic subassemblies should be cleaned by wiping with cloth or sponge soaked in neutral detergent solution, followed by washing with clean water.

(2)After the cleaned vehicle is air dried,grease the chain and run the engine at idling speed for a few minutes.

(3)Prior to driving,carefully check braking system repeatedly and repair or adjust it if necessary.

## Maintenance in Non-use Time

### Storage and Maintenance

For the motorcycle to be stored for a long period of time, attention should be paid to the prevention of moisture, sunshine and rain attack in order to protect it from unnecessary damage. Special check-ups should be carried out on those important parts and subassemblies before storage.

① Change lubricating oil.

② Grease the chain.

③ Drain off fuel from the fuel tank and carburetor (for the vehicle not to be used for over a month, the fuel in the latter must be thoroughly drained away), turn off the fuel cock and fill antirust solution into the fuel tank, followed by closing the tank with the cover.

### **Caution:**

*As fuel is inflammable, the engine should be stopped before filling or drain fuel and it is prohibited to smoke at the fuel storing, filling or draining location.*

④ Take out the spark plug, fill about 15–20ml of clean lubricating oil into the cylinder, step down the kick lever repetitively for several times and finally fit the spark plug back on.

### **Attention:**

*The ignition switch key must be set to "OFF" position before stepping down the kick lever. To protect the ignition system from damage, the spark plug should be put on its cap and earthed.*

⑤ Dismantle the battery and put it in a shady, cool and well-ventilated place. It is suggested that the battery be charged once a month.

⑥ Clean the vehicle, spray the colored part with color fastening agent and apply antirust oil to the part vulnerable to rust.

⑦ Inflate the tyre as required and pad the vehicle up with the two wheels clear of the ground.

⑧ Put the covering over the motorcycle.

## Resumption of Service

① Remove the cover and clean the vehicle. Change the lubricating oil if the vehicle has been off service for over 4 months.

② Charge the battery and remount it.

③ Drain off the antirust solution from the fuel tank, followed by filling fuel therein to the required level.

④ Prior to driving, test the vehicle at low speed in a safe place.

### Maintenance Routine Diagram

The vehicle should be under good maintenance as specified in the following table, where;

"I" means: Check, cleaning, adjustment, lubrication and/or replacement are needed.

"C" means: Cleaning is needed.

"R" means: Replacement is needed.

"A" means: Adjustment is needed.

"L" means: Lubrication is needed.

"\*" means: This item of maintenance should be carried out at a service center. It may be also done by the user himself with reference to this manual provided he has special tools, sparts and is capable of this job.

"\* \*" means: This item can only be carried out by the serviceman at General Accessories Corp. service center in order to ensure safety.

*Notes: 1. Maintenance should be conducted more frequently when the motorcycle drives in dusty areas.*

*2. When the read-out of the odometer exceeds the maximum figures specified in the table, maintenance should be still cycled according to the interval of mileage stated herein.*

**MAINTENANCE SCHEDULE**

ITEM SERVICED	PROCEDURE	621MI (1000KM)	1243MI (2000KM)	2485MI (4000KM)	3728MI (6000KM)	NOTE	ITEM SERVICED	PROCEDURE	621MI (1000KM)	1243MI (2000KM)	2485MI (4000KM)	3728MI (6000KM)	NOTE
FUEL SYSTEM ACCESS	INSPECT		X	X	X		REAR BRAKING SYSTEM	INSPECT	X	X	X	X	
FUEL FILTER	CHANGE	X	X	X	X		BRAKE FLUID HOSE	INSPECT REPLACE EVERY 4 YEARS	X	X	X	X	
THROTTLE OPERATING SYSTEM	INSPECT	X	X	X	X	2	BRAKE FLUID CLIP	INSPECT					
CARBURETOR THROTTLE RESISTANCE	INSPECT		X	X	X	2	BRAKE FLUID	INSPECT	CHANGE EVERY 2 YEARS				3
AIR CLEANER FILTER	CHANGE		X	X	X		BRAKING SYSTEM	INSPECT	X	X	X	X	
SPARK PLUGS	INSPECT	X	X	X	X	2	REAR BRAKE SWITCH	INSPECT	X	X	X	X	
VALVE CLEARANCE	INSPECT	X	X	X	X	4,2	FRONT LAMP BULB	INSPECT	X	X	X	X	
ENGINE LUBRICANTS	CHANGE 600KM, THEN EVERY 2000KM	X	X	X	X	1	CLUTCH	INSPECT	X	X	X	X	2
LUBRICATING OIL FILTER	CHANGE REPLACE ANNUALLY		X	X	X		SIDE SUPPORT	INSPECT		X	X	X	
CARBURETOR IDLE SPEED	INSPECT	X	X	X	X		SUSPENSION	INSPECT	X	X	X	X	
DRIVE CHAIN	INSPECT/LUBRICATE	X	X	X	X	2	NUTS, BOLTS, FASTENERS	INSPECT	X	X	X	X	
BATTERIES	INSPECT EVERY MONTH	X	X	X	X	5	WHEEL SPOKE	INSPECT	X	X	X	X	
BRAKE SHOE	INSPECT		X	X	X		TIRES	CHECK CONDITION, PRESSURE, TREAD	X	X	X	X	4

**NOTES:**

1. Perform annually or at specified interval, whichever comes first
2. Should be performed by an authorized SSR dealer, unless you have proper tools, data
3. Change D.O.T. 4 fluid and flush brake and clutch systems every 2 years
4. May vary with frequency of operation and riding style
5. Perform annually

## Remote-Controller's Function Operation And Instructions

Function operation:

- Set acoustic-optic anti-theft:

Press the button The horn will sound & the turnlight flash once. Three seconds later, be in the warning state of acoustic-optic antitheft.

- Anti-theft sensing:

In the state of anti-theft, any shock to the motorcycle makes the system present impedance followed with horn sounding once & turnlight flashing once. Increase of further harassing activities within the following three seconds, the system is to sound the alarm immediately; horn ringing, turning-light flashing and engine being locked automatically. remain warning state after the alarm stopped automatically. In case the motorcycle is stolen, electric switch shall flashing and engine being locked automatically.

- Anti-theft relieving:

In the state of anti-theft, press the button and the horn will sound twice & the light flash twice to relieve the state of anti-theft.

- Remote-control starting:

Press the button to ignite and drive the motorcycle

without start. If difficult, press the button longer till starting.

Press the button to stop the motorcycle in the state of remote-control starting.

- Anti-rob:

In the state that the engine is working, press the button to stop the motorcycle in such emergencies as being robbed of or stolen.

- Acoustic-optically target-seeking:

Set acoustic-optic anti-theft, three seconds later, press the button for horn and light flash so as to find the motorcycle at the parking lot.

Instructions to remote-controller use.

- The function of remote-control starting only applies to the motorcycles which is equipped with automatic transmission or able to electrically start.

- Pay attention to the prevention of soaking, hard throwing and high temperature to avoid natural loss of electrical power.

- Do not put the keys to the remote-controller into the lock.

# ELECTRICAL DIAGRAM

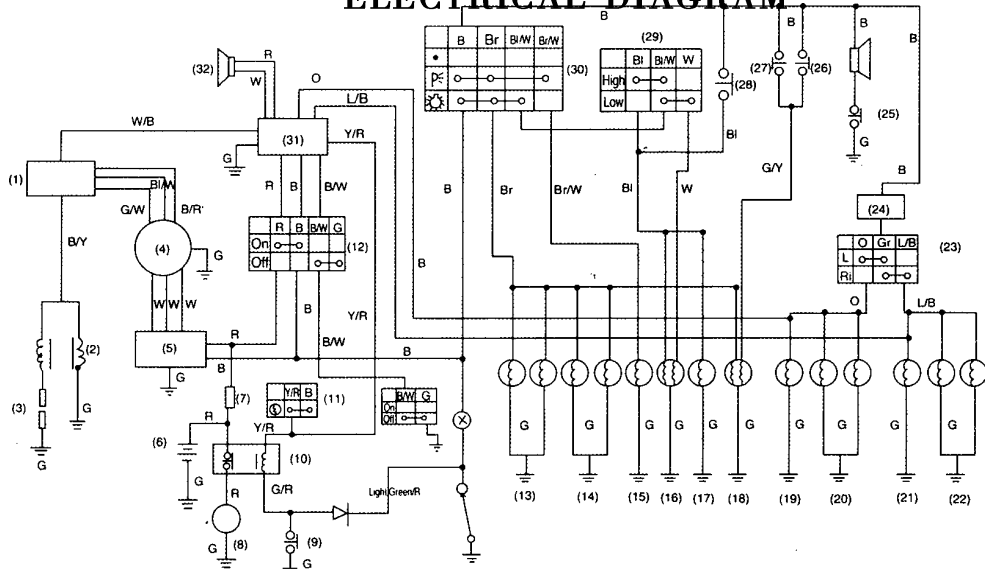

- 1.CDI
- 2.Ignition coil
- 3. Spark plug
- 4.Generator
- 5.Voltage regulator
- 6.Battery
- 7.Overflow protector
- 8.Start motor
- 9.Clutch switch
- 10.Start relay

- 11.Power Switch
- 12.Ignition
- 13.braking light
- 14.Meter light
- 15.front Position Light
- 16.Headlight
- 17.High beam indicator
- 18.Tailight/braking light
- 19.Left turn indicator
- 20.Left turn Light

- 21.Right turn indicator
- 22.Right turn light
- 23.Turnlight switch
- 24.Flasher
- 25.Worn switch
- 26.Rear braking switch
- 27.Front braking switch
- 28.Overtaking Light Switch
- 29.Light changing Switch
- 30.Illuminator switch
- 31.Burglar alarm

32.Horn

- Gr-grey B-Black Y-Yellow P-Pink
- L-Left W-White BL-Blue L/B-Light Blue
- Ri-Right R-Red O-Orange Br-Brown