

MODEL NUMBER:

SERIAL NUMBER:

GT650, GT1500

MINI TRENCHER

User Manual

Original Instructions

Instructions for Safety, Operation and Maintenance



**FOR YOUR SAFETY:
READ AND UNDERSTAND THE ENTIRE MANUAL BEFORE OPERATING THIS MACHINE!**

To maximize the life of your machine, it needs to be serviced and maintained at every indicated month or operating hour interval, whichever comes first, in accordance with the below Schedules. Please note that failure to service your machine on schedule or use genuine parts and consumables will result in your warranty being void.

Engine Service & Maintenance Schedule

Item	Checks/Work	Each Use	20hrs (1st Month)	50hrs (2nd Month)	100hrs (6th Month)	300hrs (Yearly)
Engine Oil	Check Level	X				
	Change		X (1)		X	
Air Filter	Check	X				
	Clean			X (3)		
	Replace					X (4)
Sediment Cup	Clean				X	
Spark Plug	Check/Clean				X	
	Replace					X
Idle Speed	Check/Adjust					X (2)
Valve Clearance	Check/Adjust					X (2)
Fuel Tank Strainer	Check/Clean					X (2)
Combuster Chamber	Inspect/Clean					X (2)
Fuel Lines	Check					X (2)
Engine Oil	10w-30					
Gasline fuel	#92					

Machine Service & Maintenance Schedule

Item	Checks/Work	Each Use	Weekly	20hrs (1st Month)	50hrs (2nd Month)	100hrs (6th Month)	300hrs (Yearly)
Grease Main Bearing	Check Level	X					
Fasteners Tension	Check	X					
Clean Machine	Clean	X					
Inspect Clutch	Check/Adjust						X (2)
Drive Belt	Check/Adjust		X				
	Replace						X (2)
All Other Moving Parts & Cables	Lubricate	X					X (2)

1 – First service only, 2 = Should be carried out by your Dealer, 3 = May need to be done more often in dusty areas & 4 = Replace paper element only

Table of Contents

PART I: General Safety Rules.....	6
PART II: Familiar with Your Trencher.....	13
PART III: Operating the Trencher.....	16
PART IV: Maintaining Your Trencher.....	21
PART V: Transporting and Storing.....	23
PART VI: Troubleshooting and Parts List.....	25

Conventions used in this manual

WARNING

This indicates a hazardous situation, which, if not avoided, could result in death or serious injury.

CAUTION

This indicates a hazardous situation, which, if not avoided, could result in minor or moderate injury.

NOTICE

This information is important in proper using of your machine. Failure to follow this instruction could result in damage to your machine or property.

Additional Information and Potential Changes

We reserve the right to discontinue, change, and improve its products at any time without notice or obligation to the purchaser. The descriptions and specifications contained in this manual were in effect at printing. Equipment described within this manual may be optional. Some illustrations may not be applicable to your machine. Neither the machine as a whole nor its internal components are intended for use in potential explosive atmospheres.

PART I: General Safety Rules

Safety Labels May Be Found on Your Unit

WARNING AND SAFTY INSTRUCTIONS

OPERATOR SAFETY

- Always wear the proper clothing and protective gear. Eye and ear protection, hard hat, boots, gloves and dust masks are that may be required.
- Keep hair, fingers, and all other body parts away from openings and moving parts. Always wear long pants, boots, and gloves. Secure hair so it is above shoulder length.
- Do not operate trencher indoors, outdoor use only.
- Do not operate trencher when tired, ill, or under the influence of alcohol, drugs, or medication.
- Always assume the digging location contains underground utilities. Contact appropriate utility company to determine where electrical cables, gas lines, water lines, etc. are buried before operation.
- Always use extreme caution while operating tool. Be sure of your footing and physical capabilities.

TOOL SAFETY

- Inspect entire trencher before each use. Replace damaged or worn parts.
- Check for fuel leaks and make sure all fasteners are in place and securely fastened.
- Replace digging blades that are severely worn. Be sure the digging chain and engine is not moving.

MAINTENANCE SAFETY

- Maintain according to recommended procedures included in this manual.
- Disconnect the spark plug wire before performing maintenance.
- Stop engine before removing fuel cap.
- Use only genuine replacement parts of the engine manufacturer.

FUEL SAFETY

- Refuel outdoors and where no sparks and flames.
- Store fuel in a container approved for gasoline.
- Do not smoke or allow smoking near fuel or the trencher or while using the trencher.
- Clean up all fuel spills before starting engine.
- Move at least 10 feet away from fueling site before starting engine.
- Stop engine before removing fuel cap.

DIGGING SAFETY

- Be sure that the area is clear of potential hazards, such as pipes, rocks or other materials that could possibly entangle itself around the digging chain or cause unstable footing before using the trencher.
- Keep others bystanders and helpers outside a 15 foot hazard zone from the trencher.
- Hold the trencher handle firmly with both hands.
- Keep all your body and clothing away from the digging chain, auger and other moving parts.
- Inspect the digging site. Soil, job specifications and operator experience may dictate that a different trencher or method be used to do the job.
- Do not leave trenches open or unmarked.

TRANSPORTATION AND STORING

- Always shut off the fuel valve and engine.
- Always allow the engine to cool.
- Store trencher and fuel where fuel vapors cannot reach sources of combustion like, water heaters, electric motors, switches, furnaces, etc.
- Always secure this trencher with tie downs or similar restraints when transporting.
- The trencher shall be stored in a manner that prevents it from falling, rolling or tipping over.

! DANGER !

! WARNING

● **KEEP CLEAR**

Foot Crush Zone
May pinch your foot,
cause serious injury.
Keep Back!!

! WARNING

● **KEEP BACK**

Rotating shaft can
cause severe injury.
Keep arms, legs, hair
and loose clothing away

Lifting points are identified
by lifting decals. Lifting at
other points is unsafe and
can damage machinery.

 **TRENCHER**

	<p>⚠ DANGER KEEP CLEAR</p> <p>Moving Digging Teeth will kill you or cut off arm or leg. Stay Away!</p>
---	---

	<p>⚠ WARNING</p> <p>Always wear Hearing protecting when operating the trencher</p>
---	--

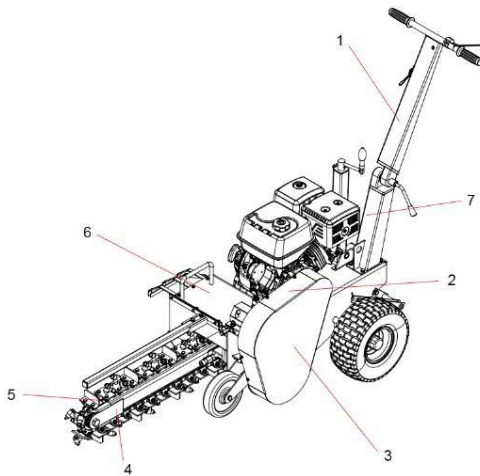

Reference#	Description
1	TRENCHER
2	WARNING
3	WARNING AND SAFETY INSTRUCTIONS
4	KEEP BACK WARNING
5	KEEP CLEAR WARNING
6	WRING LEG HAZARD
7	LIFTING LABEL

This machine can cause serious injury to the operator and bystanders. The warning and safety instructions in this manual must be followed to provide reasonable safety and efficiency in using and storing. The operator is responsible for following the warnings and instructions in this manual and the trencher. Read the entire Operator's Manual before using this trencher! Restrict the use of this trencher to persons who read, understand, and follow the warnings and instructions in this manual and on the trencher. If you have not read and understand the warnings and instructions in this manual and on the trencher, you are not qualified to operate this trencher! Become familiar with the operation and service recommendations to ensure the best performance of your machine.

Propose

CAUTION

This machine is designed solely to dig trench and must not be used for any other purpose. It should only be used by trained operators who are familiar with the content of this manual. It is potentially hazardous to fit or use any parts other than your dealer parts. We disclaim all liability for the consequences of such use, which in addition voids the machine warranty.

Before using the Trencher

NOTICE

- A. Operators must be fully trained before using this machine.
 - B. User Manual is read and understood.
 - C. Blades are in good condition and secure. All blades are sharpened or replaced in sets.
 - D. All fasteners are checked for tightness.
-

When using the Trencher

WARNING

- A. Maintain strict discipline at all times and service machine at specified periods.
 - B. During working, people should stand in the middle of the two handles, and keep a certain space from engaged wheel, so that avoid injuries of foot touching engaged wheel during walking.
 - C. Keep body parts, foreign objects and clothing clear of rotating auger and digging chain.
 - D. Coming into contact with buried utilities while digging can cause severe injuries or DEATH.
 - E. Contact appropriate utility representatives to determine if/where electrical cables, gas lines, water lines, etc. are buried BEFORE operation.
 - F. DO NOT operate the machine while under the influence of alcohol or drugs.
 - G. Only use the machine in daylight or illuminance above 500lux. Never operate the dumper after dark.
-

Protecting Yourself and Those around You

WARNING

This is a high-powered machine, with moving parts operating with high energy. You must operate the machine safely. Unsafe operation can create a number of hazards for you, as well as anyone else in the nearby area. Always take the following precautions when using this machine:

- A. Keep in mind that the operator or user is responsible for accidents or hazards occurring to other people, their property, and themselves.
- B. Always wear protective goggles or safety glasses with side shields while using the Trencher to protect your eyes from possible thrown debris.
- C. Avoid wearing loose clothing or jewelry, which can catch on moving parts.

- D. Wear shoes with non-slip treads when using your Trencher. If you have safety shoes, we recommend wearing them. Do not use the machine while barefoot or wearing open sandals.
 - E. Wear earplug when using your trencher to avoid noise.
 - F. Keep bystanders at least 50 feet (15m) away from your work area at all times. Stop the engine when another person or pet approaches.
-

Safety for Children and Pets

WARNING

Tragic accidents can occur if the operator is not alert to the presence of children and pets. Children are often attracted to the machine and the digging activity. Never assume that children will remain where you last saw them. Always follow these precautions:

- A. Keep children and pets at least 50 feet(15m) from the working area and ensure they are under the watchful care of a responsible adult.
 - B. Be alert and turn the machine off if children or pets enter the work area.
 - C. Never allow children to operate the Trencher.
-

Safety with Gasoline - Powered Machines

WARNING

Gasoline is a highly flammable liquid. Gasoline also gives off flammable vapor that can be easily ignited and cause a fire or explosion. Never overlook the hazards of gasoline. Always follow these precautions:

- A. Never run the engine in an enclosed area or without proper ventilation as the exhaust from the engine contains carbon monoxide, which is an odorless, tasteless, and a deadly poisonous gas.
- B. Store all fuel and oil in containers specifically designed and approved for this purpose and keep away from heat and open flame, and out of the reach of children.
- C. Replace rubber fuel lines and grommets when worn or damaged and after 5 years of use.
- D. Fill the gasoline tank outdoors with the engine off and allow the engine to cool completely. Don't handle gasoline if you or anyone nearby is smoking, or if you're near anything that could cause it to ignite or explode. Reinstall the fuel tank cap and fuel container cap securely.
- E. If you spill gasoline, do not attempt to start the engine. Move the machine away from the area of the spill and avoid creating any source of ignition until the gas vapors have dissipated. Wipe up any spilled fuel to prevent a fire hazard and properly dispose of the waste.

- F. Allow the engine to cool completely before storing in any enclosure. Never store a machine that has gasoline in the tank, or a fuel container, near an open flame or spark such as a water heater, space heater, clothes dryer or furnace.
 - G. Never make adjustments or repairs with the engine running. Shut down the engine, disconnect the spark plug wire, keeping it away from the spark plug to prevent accidental starting, wait 5 minutes before making adjustments or repairs.
 - H. Never tamper with the engine's governor setting. The governor controls the maximum safe operation speed and protects the engine. Over-speeding the engine is dangerous and will cause damage to the engine and to the other moving parts of the machine. If required, see your authorized dealer for engine governor adjustments.
 - I. Keep combustible substances away from the engine when it is hot.
 - J. Never cover the machine while the muffler is still hot.
 - K. Do not operate the engine with the air cleaner or the carburetor air intake cover removed. Removal of such parts could create a fire hazard. Do not use flammable solutions to clean the air filter.
 - L. The muffler and engine become very hot and can cause a severe burn; do not touch.
-

General Safety



WARNING

Operating this Trencher safely is necessary to prevent or minimize the risk of death or serious injury. Unsafe operation can create a number of hazards for you. Always take the following precautions when operating:

- A. Your Trencher is a powerful tool, not a plaything. Exercise extreme caution at all times. The machine is designed to dig trench. Do not use it for any other purpose.
- B. Know how to stop the Trencher quickly.
- C. Exercise caution to avoid slipping or falling.
- D. See manufacturer's instructions for proper operation and installation of accessories.
- E. Never use the machine without ensuring that all guards and shields are in place.
- F. Never, under any conditions, remove, bend, cut, fit, weld, or otherwise alter standard parts on the Trencher. This includes all shields and guards. Modifications to your machine could cause personal injuries and property damage and will invalidate your warranty.
- G. If the machine start to make an unusual noise or vibrate, shut down the engine, disconnect the spark plug wire, keeping it away from the spark plug to prevent accidental starting, wait 5 minutes for engine to cool down, then inspect for damage. Vibration is generally a warning of trouble. Check damaged parts and clean, repair and/or replace as necessary.

- H. Never tamper with safety devices. Check their proper operation regularly.**
 - I. Before performing any maintenance or inspection procedure, shut down the engine, disconnect the spark plug wire keeping it away from the spark plug to prevent accidental starting, wait 5 minutes for machine to cool down.**
 - J. Never allow people who are unfamiliar with these instructions to use the Trencher. Allow only responsible individuals who are familiar with these rules of safe operation to use your machine.**
 - K. Never overload or attempt to dig trenches beyond the manufacturer's recommendation. It could result in personal injury or damage to the machine.**
 - L. While using, don't hurry or take things for granted. When in doubt about the equipment or your surroundings stop the machine and take time to look things over.**
 - M. Never operate the machine when under the influence of alcohol, drugs, or medication.**
 - N. Use the machine only in daylight.**
 - O. Stay alert for hidden hazards or traffic.**
 - P. Keep all nuts and bolts tight and keep the equipment in good operating condition.**
-

A Note to All Users

List of warnings and cautions cannot be all-inclusive. If situations occur that are not covered by this manual, the operator must apply common sense and operate this TRENCHER in a safe manner. Contact the dealers for assistance in your area.

PART II: Familiar with Your Trencher

It may be helpful to familiarize yourself with the controls and features of the Trencher. If you have any question, please contact the dealers in your area.

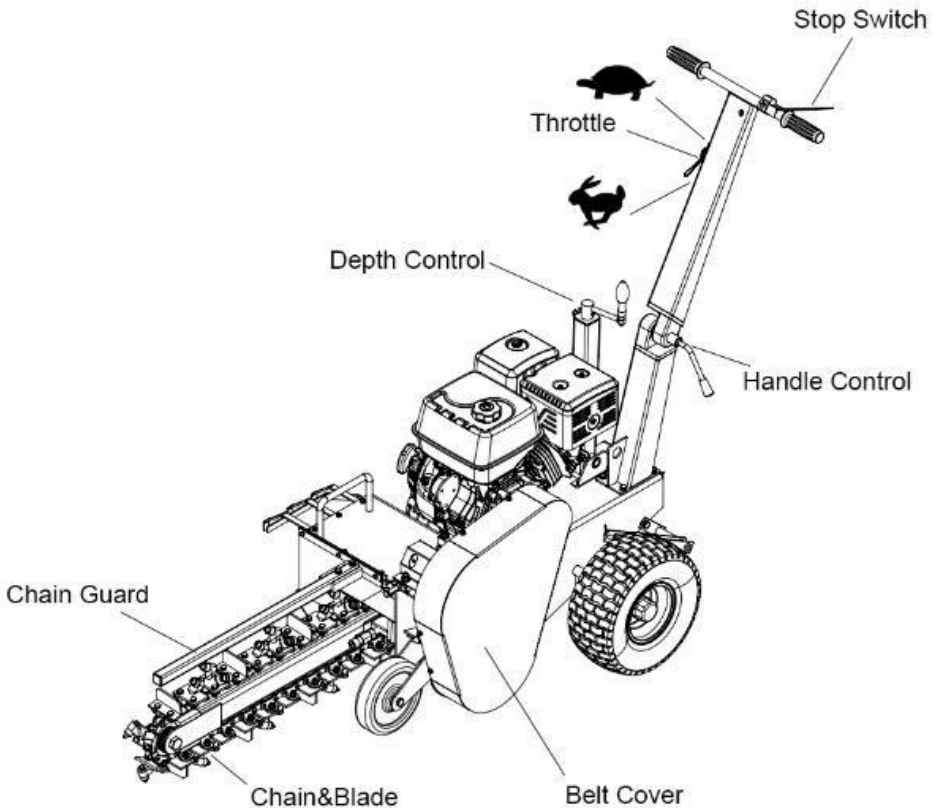

 : When we push forward, the throttle increases and the speed faster.

 : When we pull back, the throttle reduces and the speed slower.

TECHNICAL SPECIFICATIONS

	Trencher GT650	Trencher GT1500
Engine	6.5/7hp four strokes	13/13.5/15hp four strokes
Power	Gasoline/Petrol	Gasoline/Petrol
Trench Capacity	60m/hour	60m/hour
Trench Width	100mm	100mm
Trench Depth	150,250,340,450mm	200,400,600mm
Blade	21 carbide alloy blades	27 carbide alloy blades
Chain Length	1600mm	2000mm
Chain Speed(Max)	550m/min	550m/min
Tire	145/7.0-6	145/7.0-6
Overall Height	900mm	1100mm
Overall Length	1760mm	2100mm
Overall Width	700mm	720mm
Weight	136kgs	188kgs
Noise	A-weighted sound power level LW(A)=112.4dB A-weighted Sound pressure LpA=88.8dB	A-weighted sound power level LW(A)=110.8dB A-weighted Sound pressure LpA=88.6dB
Vibration Values	12.38 m/s ²	9.99 m/s ²

NOTICE

- A. It is your responsibility as the operator of this piece of equipment to know what specific requirements, precautions and work hazards exist. You must read and understand all of the information contained in the user manual.
- B. The trencher is a small, operator propelled, chain-type trencher designed for the installation of lines that require a narrow shallow trench. It has more than enough power to trench through the toughest soils, however, because of its small size, low horse power and trench capacity, it is limited in what it is

- capable of doing. The job site, soil conditions, job specifications and operator experience may dictate that a different tool or method be used to do the job.
- C. The digging chain has a tendency to pull the trencher in the opposite direction you want to dig. For this reason, be sure that the digging teeth are not in contact with the ground or other objects while starting the engine and that the wheel lock device engages before lowering the digging bar into the ground. Be sure that you have a firm grip on the machine and are ready to control it when the digging bar comes in contact with the ground.
 - D. The trencher has a tendency to “hop” or “buck” under certain conditions. This can be the result of certain soil conditions or buried objects that the trencher cannot cut through or lift to the surface. The trencher must be stopped and the object removed, or restarts the trench beyond the object.
-

PART III: Operating the Trencher

It may be helpful to better familiarize yourself with the features of your Trencher before beginning the steps outlined in this chapter.



CAUTION

- A. Read and understand all instructions, safety precautions, and/or warnings listed in “PART I: General Safety Rules” before operating the TRENCHER. If any doubt or question arises about the correct or safe method of performing anything found in this manual, please contact the dealers in your area.
 - B. Before loading and operating the Trencher, always wear protective gear, including safety goggles, hearing protection, tight-fitting gloves without draw strings or loose cuffs, and steel-toed shoes.
-

Starting

Be sure the depth control is in the “0” depth position and move both stop switches to the “ON” position. Always stand to the rear of the trencher, away from the side delivery auger and digging chain while starting the engine. Always start the trencher at the job site and allow it to warm up. While the machine is running, check that all controls are working properly before using.

Start the engine following the procedures:

1. Make sure the fuel shut-off valve is in the “ON” position.
2. Move the choke control lever to the “CHOKE” position (should only be needed if the engine is cold).
3. Move the throttle control lever to the “FAST” position.
4. Recoil Start: Turn the Ignition Switch to the “On” position. Push the handle of flameout switch and grasp the recoil starter handle and slowly pull until you feel resistance. Let the cord retract a little bit then pull the cord rapidly to start the engine. One or two pulls usually starts the engine.
5. Electric Start: Turn and hold the Key in the start position until Engine starts then let the key return to run position.
6. Move the choke control lever (if used for cold engine) slowly back to the “RUN” position when the engine is running well.

7. If the Trencher has not been running (cold engine), warm up the engine by running the engine at half throttle for 3 to 4 minutes, then advance the engine throttle control to the maximum speed.

Trenching

Be sure the digging chain is not turning when the engine is at an idle. Be sure the engine is off or at an idle before moving the trencher at the job site.

NOTE: All depths are approximate. Actual depth may vary depending upon soil conditions and trencher blade wear.

Also, soil conditions and operator experience will dictate actual trenching action and speed.

A general description on how to trench:

1. Anticlockwise rotate the depth control handle and lift the chains, lock the anti-forward control handle, then the trencher can be push forward.

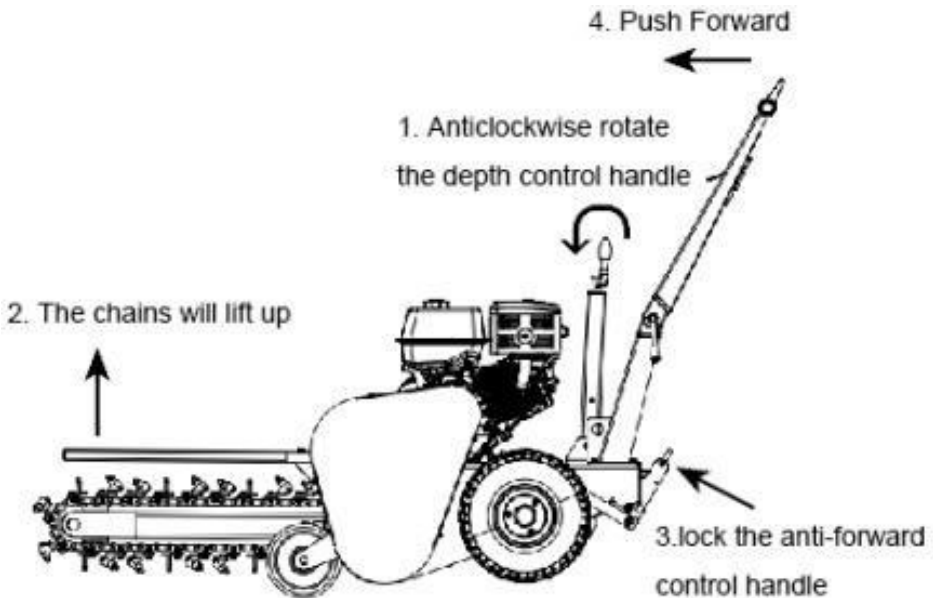

2. Push forward the trencher to the work site, loose the anti-forward control handle, then the trencher can only move backwards. Clockwise rotate the depth control handle and descend the chains to your desired depth.

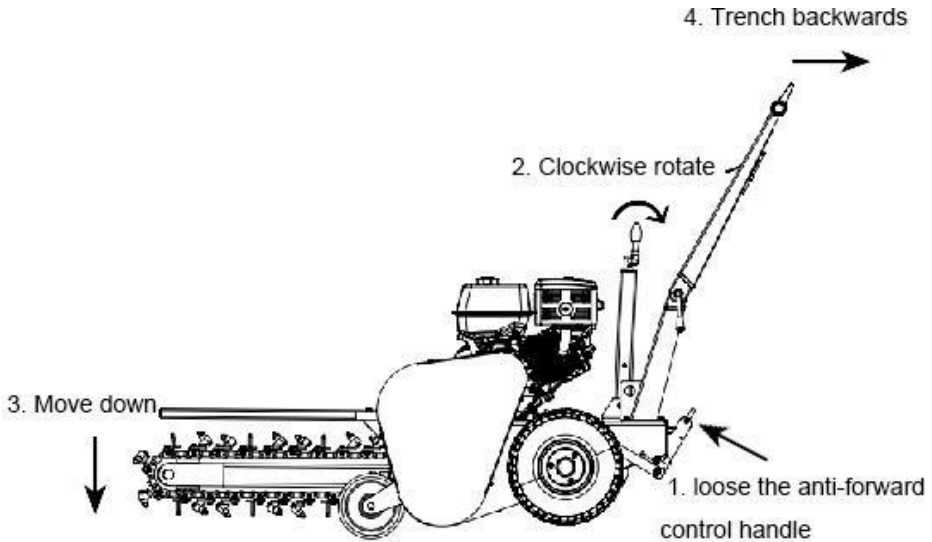

Notes:

1. Lock: When we put the anti-forward control handle in the slot, the anti-forward controller lift up, don't touch the wheel gear, we can push forward.
2. Loose: When we pull back the anti-forward control handle, it will automatically loose the anti-forward controller down on the wheel gear, the trencher can't move forward and can only move backwards.

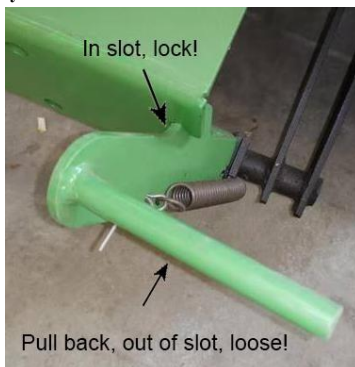

Stopping

There are two stop switches on the trencher; one on the handle bar and one on the engine. Refer to the engine manual for the switch location on your trencher. The operator can turn the trencher off at any time by switching either stop switch to the “OFF” position. Both switches must be “ON” before the engine can start.

Stopping the engine following the procedures:

1. Switching stop switch on handle.
2. Move the Throttle Lever to IDLE.
3. Recoil Start: Turn the Ignition Switch to the OFF position.
4. Electric Start: Turn the Key to the OFF position.

When Blocked

If the Chain stops moving while digging trenches, the engine should be stopped, take out the muds or anything which stuck the chain, then restart the engine, and start digging again.

Operator Safety

WARNING

- A. All the rack and pinion should be greased before every use.
 - B. Always wear the proper clothing and protective gear. Eye and ear protection, hard hat, boots, gloves and dust masks are that may be required.
 - C. Keep hair, fingers, and all other body parts away from openings and moving parts. Always wear, long pants, boots, and gloves. Secure hair so it is above shoulder length.
 - D. Do not operate trencher indoors. Outdoor use only.
 - E. Do not operate trencher when tired, ill, or under the influence of alcohol, drugs, or medication.
 - F. Always assume the digging location contains underground utilities. Contact appropriate utility company to determine where electrical cables, gas lines, water lines, etc. are buried before operation.
 - G. Always use extreme caution while operating tool. Be sure of your footing and physical capabilities.
-

Tools Safety

CAUTION

- A. Inspect entire trencher before each use. Replace damaged or worn parts.
 - B. Check for fuel leaks and make sure all fasteners are in place and securely fastened.
 - C. Replace digging blades that are severely worn. Be sure the digging chain and engine is not moving.
-

Fuel Safety

WARNING

- A. Refuel outdoors and where no sparks and flames.
 - B. Store fuel in a container approved for gasoline.
 - C. Do not smoke or allow smoking near fuel or the trencher or while using the trencher.
 - D. Clean up all fuel spills before starting engine.
 - E. Move at least 10 feet away from fueling site before starting engine.
 - F. Stop engine before removing fuel cap.
-

Digging Safety

WARNING

- A. Be sure that the area is clear of potential hazards, such as pipes, rocks or other materials that could possibly entangle itself around the digging chain or cause unstable footing before using the trencher.
 - B. Keep others bystanders and helpers outside a 15 foot hazard zone from the trencher. Hold the trencher handle firmly with both hands.
 - C. Keep all your body and clothing away from the digging chain, auger and other moving parts.
 - D. Inspect the digging site. Soil, job specifications and operator experience may dictate that a different trencher or method be used to do the job. E. Do not leave trenches open or unmarked.
-

PART IV: Maintaining Your Trencher

Regular maintenance is the way to ensure the best performance and long life of your machine. Please refer to this manual and the engine manufacturer's user manual for maintenance procedures.

Maintenance Safety

NOTICE

- A. Before performing any maintenance procedure or inspection, stop the engine, wait five minutes to allow all parts to cool.
- B. Disconnect the spark plug wire, keeping it away from the spark plug. Disconnect the Battery Terminals (Electric start only). C. Stop engine before removing fuel cap.
- D. Use only genuine replacement parts of the engine manufacturer.

Regular Maintenance Checklist

Procedure	Before Each Use	Every 3 Hours	Every 25 Hours	Every 100 Hours
Check engine oil level	Δ			
Check general equipment condition	Δ			
Check wedge for sharpness	Δ			
Grease surface of slide rail	Δ			
Check belts	Δ			
Grease rack and pinion		Δ		
Check tire pressure			Δ	
Clean engine exterior and cooling			Δ	
Change Engine Oil	First time 5hours		Δ	
Replace air filter			Δ	
Replace spark plug				Δ

Engine Service

Refer to the engine manufacturer's user manual for engine maintenance.

Lubrication

Recommended engine oil 4-stroke gasoline engine oil SF under API service classification or SAE10W-30(equivalent to SG class).

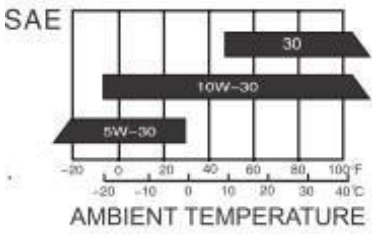

NOTICE

All Bearings of Trencher are sealed units and should have sufficient lubricant to last the life of your machine with normal use.

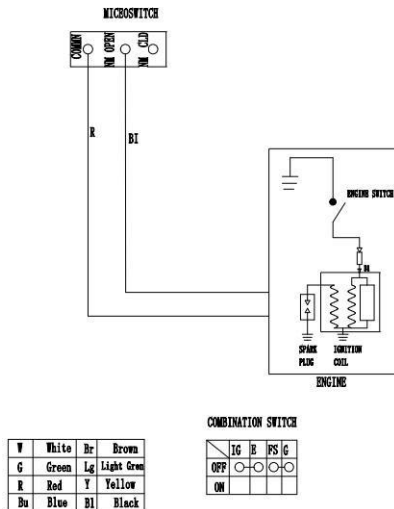

PART V: Transporting and Storing

Transporting

The mini trencher is designed to be transported via a van or small trailer. The machine is equipped with grab bars that are to be used for both lifting the machine, and strapping it down. This machine weighs approximately 188kg and should only be lifted using correct apparatus.

- 1) When the mini trencher is packaged in the plywood case, we can carry machine by forklift.
- 2) Without package, we can lift the machine at the point of lift label shown.
- 3) Tie the machine at the point of tying label when transport for long distance to keep the machine stable.

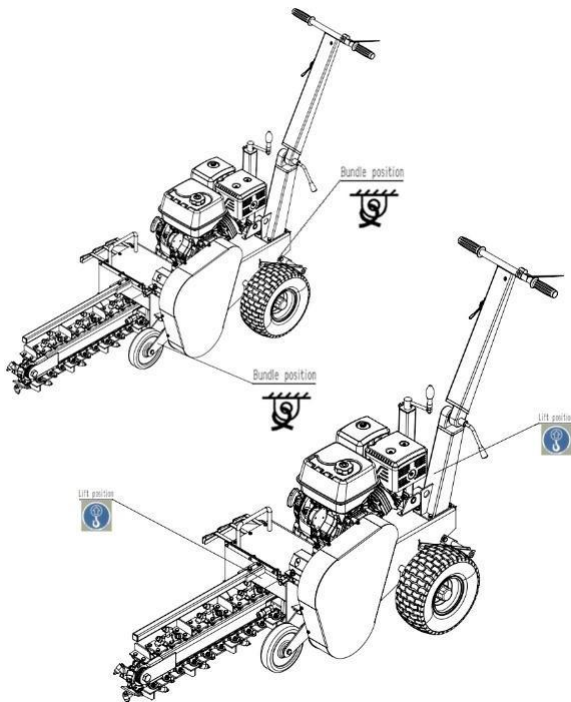

Note: There are legal road requirements for transiting mini machines. It is the owner's responsibility to be aware of these laws and to adhere to them.

Storing

When you finished using the mini trencher and it has cooled, you must:

- 1) Cool engine before storage.
- 2) Clean the dumper.
- 3) Inspect for worn or damaged parts.
- 4) Choose covered storage location.
- 5) Prevent accidental starting.
- 6) Plan on exercising the engine at least monthly unless the dumper is prepared for long term storage.



NOTICE

- A. Always shut off the fuel valve and engine.
 - B. Always allow the engine to cool.
 - C. Store trencher and fuel where fuel vapors cannot reach sources of combustion like, water heaters, electric motors, switches, furnaces, etc.
 - D. Always secure this trencher with tie downs or similar restraints when transporting.
 - E. The trencher shall be stored in a manner that prevents it from falling, rolling or tipping over.
-

PART VI: Troubleshooting and Parts List

Most problems are easy to fix. Consult the Troubleshooting Table below for common problems and their solutions. If you continue to experience problems, contact the dealers in your area.



WARNING

Before performing any maintenance procedure or inspection, stop the engine, wait five minutes to allow all parts to cool. Disconnect the spark plug wire, keeping it away from the spark plug.

Troubleshooting Table

SYMPTOM	POSSIBLE CAUSE
<p>The engine won't start.</p> <p>(Please refer to the engine user manual for engine-specific procedures.)</p>	<p>Is the ignition switch in the "ON" position?</p> <p>Is the fuel shut-off valve on?</p> <p>Are you using fresh, clean gas? If the gas is old, change it. Use a fuel stabilizer if you keep gas longer than 30 days.</p> <p>Is the spark plug clean? If the spark plug is dirty or cracked, change it. If it's oily, leave it out, hold a rag over the plug hole and pull the recoil cord several times to blow out any oil in the cylinder, then wipe off the plug and reinsert it.</p>
<p>The engine lacks power or is not running smoothly.</p> <p>(Please refer to the engine user manual for engine-specific procedures.)</p>	<p>Check that the Throttle Lever is in the "Run" position.</p> <p>Is the air filter clean? If it's dirty, change it following the procedure in the engine manufacturer's owner's manual.</p> <p>Is the spark plug clean? If it's fouled or cracked, change it. If it's oily, leave it out, hold a rag over the plug hole and pull your recoil cord several times to blow out any oil in the cylinder, then wipe off the plug and reinsert it.</p> <p>Are you using fresh, clean unleaded gasoline? If it's old, change it. Use a fuel stabilizer if you keep gasoline longer than 30 days.</p> <p>Does your engine have the right amount of clean oil? If it's dirty, change it following the procedure in the engine manufacturer's owner's manual.</p> <p>Check the oil level and adjust as needed.</p>
<p>Engine smokes.</p> <p>(Please refer to the engine user manual for engine-specific procedures.)</p>	<p>Check the oil level and adjust as needed.</p> <p>Check the air filter and clean or replace if needed.</p> <p>You may be using the wrong oil—too light for the temperature.</p> <p>Refer to your Engine Owner's Manual for detailed information.</p> <p>Clean the cooling fins if they're dirty.</p>

Explosion View:

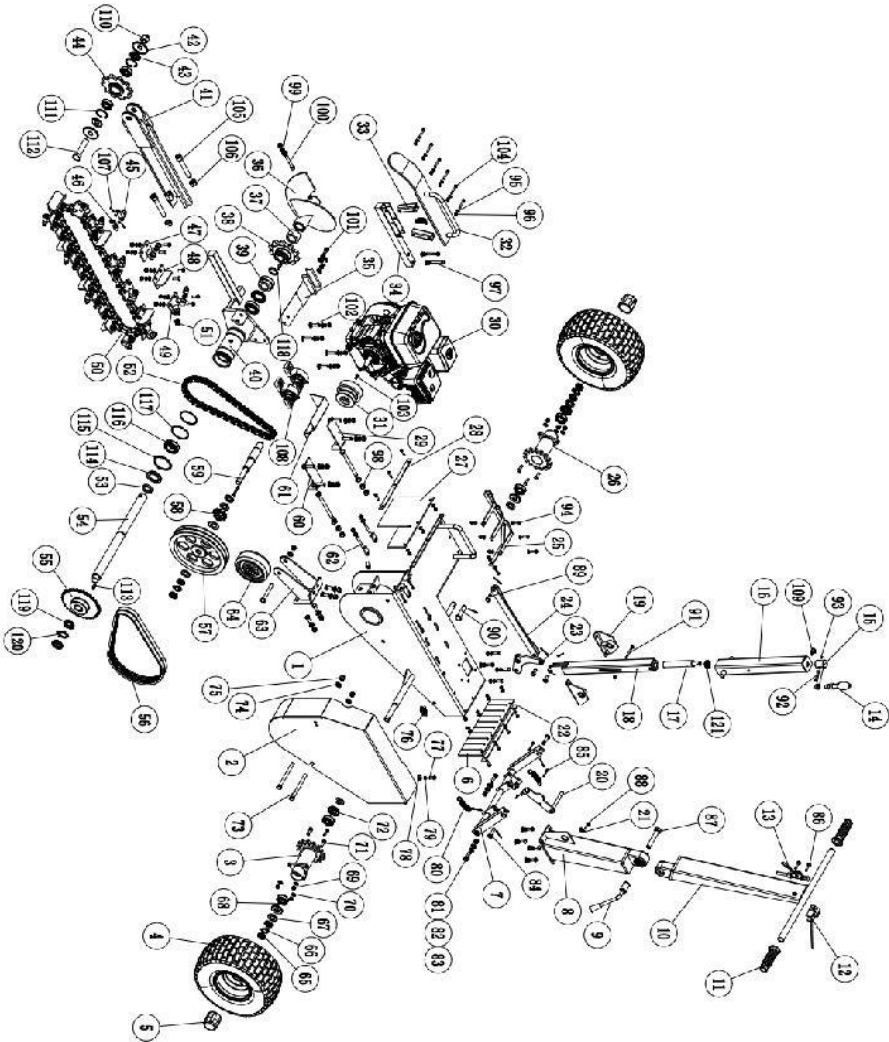

Parts List:

Ref.No.	Description	Ref.No.	Description
1	Chassis	62	Chassis component
2	Belt cover	63	Wheel mounting seat
3	Left ratchet wheel	64	6" wheel
4	Wheel	65	Round nut M20x1.5
5	Bearing cover	66	Round nut stop washer 20
6	Rubber	67	Flat washer 20
7	Halt frame	68	6204 bearing
8	Lower handle	69	Lock nut M8
9	Angle arm	70	Flat washer 8
10	Upper handle	71	Hex bolt M8x25
11	Handlebar grip	72	Oil sea 20x47
12	Flameout switch	73	Hex bolt M12x130
13	Throttle switch	74	Flat washer 12
14	Handle	75	Lock nut M12
15	Rotation handle	76	Eyebolt M8
16	Outer lift rod	77	Hex bolt M8x20
17	Thread rod	78	Flat washer 8
18	Inner lift rod	79	Spring washer 8
19	Lift rod foundation	80	Spring
20	Halt control lever	81	Hex bolt M10x35

21	Cable clamp	82	Flat washer 10
22	Rubber mounting plate	83	Lock nut M10
23	Rotation plate	84	Pin 10x40
24	Lift rod plate	85	Split cotter 3.2x32
25	Shield	86	Hex bolt M6x30
26	Right ratchet wheel	87	Hex bolt M16x90
27	Rubber	88	Hex bolt M8x30
28	Rubber mounting plate	89	Pin 10x26
29	Right fixing plate	90	Pin 16x65
30	Engine	91	Hex bolt M6x60
31	Clutch	92	Hex bolt M5x40
32	Chain cover	93	Lock nut M5
33	Chain cover support	94	Hex bolt M6x25
34	Connection arm	95	Flat washer 6
35	Connection arm plate	96	Lock nut M6
36	Ridge	97	Hex bolt M8x55
37	Ridge locating bush	98	Hex nut M10
38	Back gear	99	Spring washer 10
39	Bearing flange spacer	100	Hex socket bolt M10x70
40	Chain axle plate	101	Hex bolt M10x25
41	Chain adapter	102	Carriage bolt M8x45

42	Gear cap	103	Flat key 5x5
43	Chain spacer	104	Hex bolt M6x40
44	Front gear	105	Hex socket bolt M16x100
45	Chain lock 1	106	Hex nut M16
46	Chain lock 2	107	Split cotter 1.6x18
47	Single blade holder	108	UCP205 bearing
48	Blade	109	Libricating cup M10x1
49	Dual blade holder	110	Lock nut M20
50	Chain	111	Spring washer 47
51	Alloy carbide teeth	112	Hex bolt M20x90
52	Drive chain	113	Flat key 8x7
53	Locating bush	114	Oil seal 42x62
54	Gear axle	115	Spring washer 75
55	Gear wheel	116	Bearing 32007
56	Belt	117	Seal ring 69x3.55
57	Pulley	118	Spring washer 35
58	Drive gear	119	Round nut 30x1.5
59	Drive axle	120	Lock washer 30
60	Left fixing plate	121	Bearing 51102
61	Bearing cover		