

1.Preface.....	1
2. Function Summary	2
3.Main Technical Parameters	3
4.Main Structure and Working Principle & Adjustment Method	4
5.Panel Function Declaration	8
6.Direction For Using	9
7.Electrical Schematic Diagram	12
8.Parts Exploded Views & Names	13
9.Trouble Shooting of Common Fault	35
10.Maintenance	36

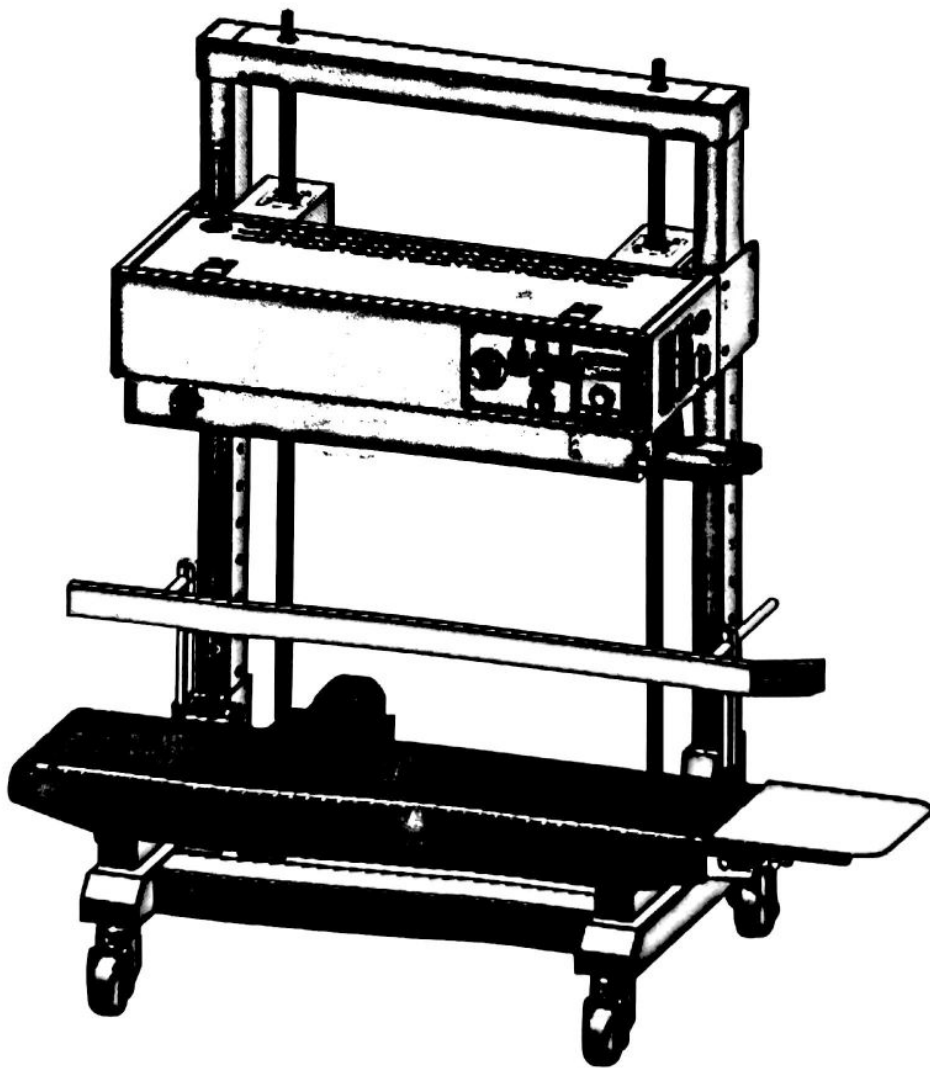

FR-1100V、FRD-1200V

(Vertical sold-inker coding band sealer
Manual book)



1.Preface

Thanks for choosing FR-1100V, FRD-1200V vertical sold-inker coding band sealer which research and development, manufactured by our company. FR-1100V, FRD-1200V vertical sold-inker coding band sealer is our new type sealing machine, which is newly designed on the basis of absorbing the essence of domestic and foreign sealing machine. A new machine specially designed for the sealing of PE film packing bags. This machine is new generation of push, sealing set integrated continuous packaging machine designed according to the latest market demand. The machine can adjust the comfort level according to the height of the operator, and the sealing position can be adjusted according to the height of the item. The structure is simple and novel, the appearance is beautiful and fashionable, the function is complete, the automation degree is high, can greatly reduce the labor intensity of the operator. It has the advantages of safety, reliability, simple operation, high vacuum, fast heating, beautiful sealing, etc.

In order to operation machine properly and utilize its value best, read this operational instruction carefully before utilization. This will help you to grasp the machine's basic mechanical principle, structure, operational process and maintenance method. The malfunction will be reduced if you have proper operational method, and make the life of machine is prolonged.

SPECIAL STATEMENT:

- 1. As to the all parameters and content in this book, we have final right of interpretation.**
- 2. We remain the right of improving technology of product, and it will not be notified separately.**



2.Function Summary

This Sealer is suitable for sealing and making various plastic film bags, it widely used in the fields of food, medicine, chemical industry, daily expenses and so on.

Because of this sealer adopts electronic constant temperature control and infinite adjustable-speed drive mechanism, it can seal all kinds of different materials of plastic bags. Because of the machine is in small size, wide application, and the sealing length is not restricted, it can be used with many kinds of packing production line. It will be the best sealing equipment for factories and shops to pack batch products.

Due to the electrical control is simple and the mechanical transmission is reasonable and refined, thus structure performance is very stable, failure rate is extremely low, and lasts longer life. It can work continuously for a long time; can meet the demand of mass production. After the products are sealed by this machine, they will have good appearance, clean and tidy, dustproof, moisture proof, breakage-proof, and easy to carry and store. Greatly reduce product loss and packing cost.



3. Main Technical Parameters

Model Item	FR-1100V	FRD-1200V
Power	110/220V/50~60Hz	
Voltage	1.235Kw	1.355Kw
Sealing speed (m/min)	0~12	0~12
Sealing height	80~600mm	80~600mm
Sealing Width (mm)	6~12	6~12
Temperature Range	0~300	0~300
Single layer film Max thickness (mm)	≤0.08	≤0.08
Conveyor max loading weight (Kg)	≤15	≤15
Machine Size (LxWxH) mm	1243×580×1228	1371×580×1228



4.Main Structure and Working Principle & Adjustment Method

4.1 Main Structure outside drawing (Figure 1)

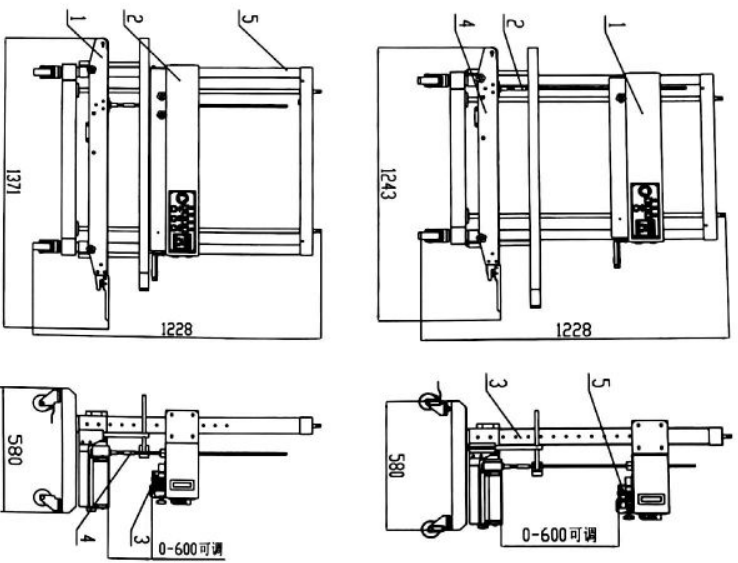

- (1) Conveyor part
- (2) Machine frame and sealing parts
- (3) Sealing part
- (4) Umbrella gear mechanism
- (5) Vertical frame

3.2 Working Principle

After being connected to the power supply, each device begins to work, the electro-thermal parts generate heat to heat up bottom and up heating block rapidly. When the temperature reaches at the setting temperature of temperature controller, putting the sealing part of plastic bag into the position between two sealing belts, then it conveys into the heating area which among bottom and up heating block, the plastic sealing part will be sealed by melt through heating and extruding by roller. Then it will convey into cooling area to get into form, to make plastic bag sealing parts with stripe or reticulate (or dates) by embossing wheel rolling.

4.3. Adjustment Methods of Each Component

A. 1. Adjustment method of Conveyor part

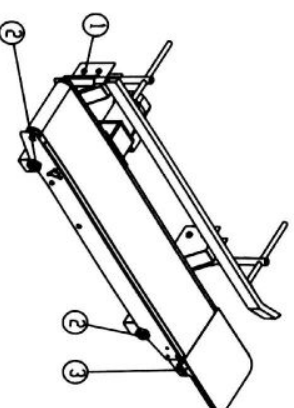

- ① Adjusting locking screw
- ② Lock knob
- ③ Conveyor belt tension wheel adjustment screw

Conveyor belt tension adjustment: when the conveyor belt is too loose or too tight, adjusting conveyor belt tension wheel adjustment screw ③ of two sides



(right rotation is to be tight, left rotation is to be loose), until the tightness of conveyor belt is appropriate.

Conveyor worktable up and down fine adjustment: when the conveyor worktable needs up and down adjustment, first to loosen two sides fasten knob

①, then pull the worktable up or down until the position is suitable.

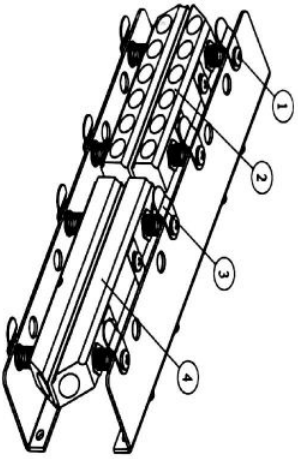

II.

Adjustment method of sealing parts

- ①. Adjustment screw
- ②. Cooling block
- ③. Lifting piece
- ④. Heating block

Distance adjustment of Up and down heating block & cooling block:

because of different sealing material and thickness, each kind of product needs to adjust the distance between heating block and cooling block. The method is described as follows: right-handed rotation adjustment screw ① can increase the distance between up and down heating blocks and cooling blocks,

Left-handed rotation adjustment screw ① can decrease the distance between up and down heating blocks and cooling blocks.

6

Sealing belt replace method & adjustment: after the heating block cool down, take down the protective cover, rotating the lifting piece ③ into 90° which on the heating block and cooling block in Figure 3, then loose the embossing wheel and the spring of middle pressure wheel, take down the leading belt, then push driven wheel in the direction of the heating block, and take down the sealing belt and replace with new sealing belt. Finally adjust the position back of driven wheel, heating blocks, cooling blocks and embossing wheel.

III. Driven belt roller adjusting blocks

- ①. Spring
- ②. driven belt wheel seat
- ③. driven wheel seat
- ④. Adjusting screw
- ⑤. Adjusting screw

If the sealing belts have phenomenon of off tracking, it can adjust the adjusting screw of driven belt wheel seat ②.

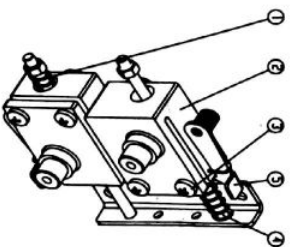

7



IV. Adjust the comfort and sealing size.

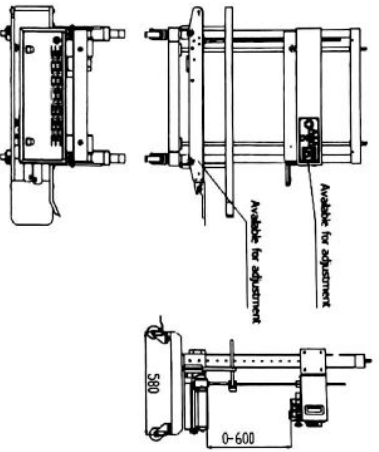

5. Panel Function Declaration

1.FR-1100V Panel instructions

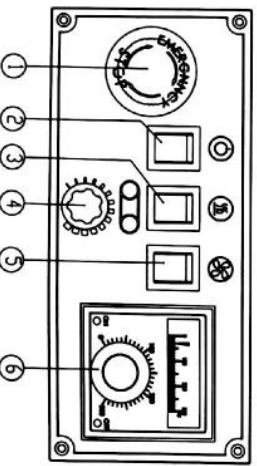

- ① . Urgent stop switch: under emergency status, disconnect the power supply.
- ② . Power switch: Control the whole machine on or off
- ③ . heating switch: control heating tube of heating block on or off
- ④ . Speed adjustment knob: control the speed of conveyor motor
- ⑤ . Fan switch: control cooling fan on or off
- ⑥ .temperature controller: adjust and control the temperature of heating block

2.FR-1100V Panel instructions

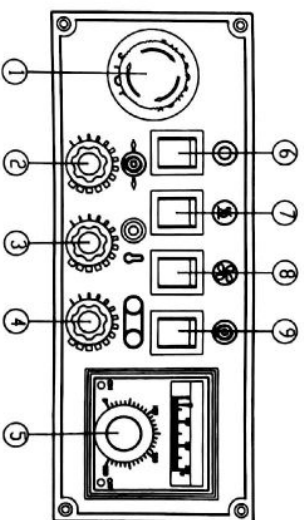

1. Urgent stop switch: under emergency status, disconnect the power supply.
2. Position switch: Adjust the left and right position of the ink wheel.
3. Lettering tempering switch: Adjust the temperature of the ink wheel heating block
4. Sealing speed switch: Control the speed of the sealing conveyor belt running
5. Temperature controller: adjust and control the temperature of heating block
6. Power switch: Control the whole machine on or off
7. heating switch: control heating tube of heating block on or off
8. Fan switch: control cooling fan on or off
9. Printing switch: Control the opening and closing of the ink wheel heating block
 - A. Turn the dial on the knob to the desired temperature.
 - B. The dial on the thermometer is the actual temperature in the medium.

6.Direction For Using

1. This machine has finished debugging before leave the factory, in order to make the machine working under the best condition, giving full play to the



- efficiency and service life; it must be operated and maintained by specialist worker. The operator has to be familiar with the whole machine debugging skills and operational procedures, and mastering the operation principle, so as not to damage the machine
2. Put the machine in flat floor, take away the outside wrappage, and well-ground connect. Before the machine is charged with electricity, all the parts should be checked without loosening, shifting, and etc., it should be adjusted in time if have found . Rotating all spindles by man-made to see if they are turning free, checking all the electric conduction leading wires to see if they broke away from the retention clips, to see if they are lapping joint, grinding ,hooking with rotation, slidable, lifting devices to impact regular work.
 3. On the basis of sealing material, adjust the suitable distance between up and down heating block and cooling block. The gap between the two sealing belts is about one layer of thickness of the bag is the best, this can ensure the sealing fastness and clear embossing, and will not make the sealing parts extend too long.
 4. On the basis of operation demand, adjusting the conveyor worktable into suitable position.
 5. Connecting with power supply and turn on the power switch, after power indicator light on, adjusting Speed adjustment knob to make all transmission parts synchronous running.
 6. Fine tuning the embossing wheel screw to make the embossing wheel running, until adjust into suitable pressure, fixing the limit screw.

7. Turn on the heating switch, after the digital temperature controller green light on, adjusting the needed temperature on the basis of plastic bag material and thickness. When the heating block start to preheat, the machine should runs slowly at the same time.
8. On the basis of plastic bag material and thickness to see if need to turn on the cooling fan.
9. Making the plastic bag alignment of sealing parts and lay down, putting the plastic bag into feed inlet, when the bag sealing part is occlusion by sealing belts, the plastic bag will move forward automatically. At this moment, please do not push or block at random, otherwise the sealing parts will be crumpled or faulted.
10. When you find the sealing belts and heating block are adhered with garbage, stop running machine to clean at once. Please do not touch them directly by hands when the temperature is high, so as not to scald or bruised.
11. In order to enhance the useful life of sealing belts, first to adjust the temperature into zero before turning off the machine. Then turn on the cooling fan, the sealing belts should be normal running at the same time, cannot stop. After a period of time, to ensure the temperature of the heating block is under 80 ℃, then can turn off the cooling fan and the power switch.



7. Electrical Schematic Diagram

1. FR-1100V circuit diagram

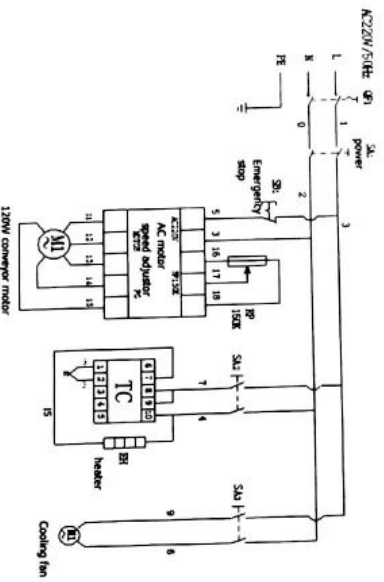

2. FR-1100V circuit diagram

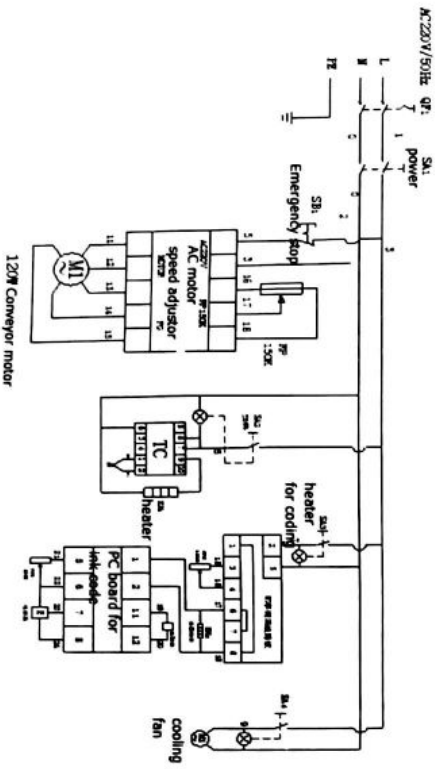

8. Parts Exploded Views & Names

1. FR-1100V Parts Exploded Views & Names

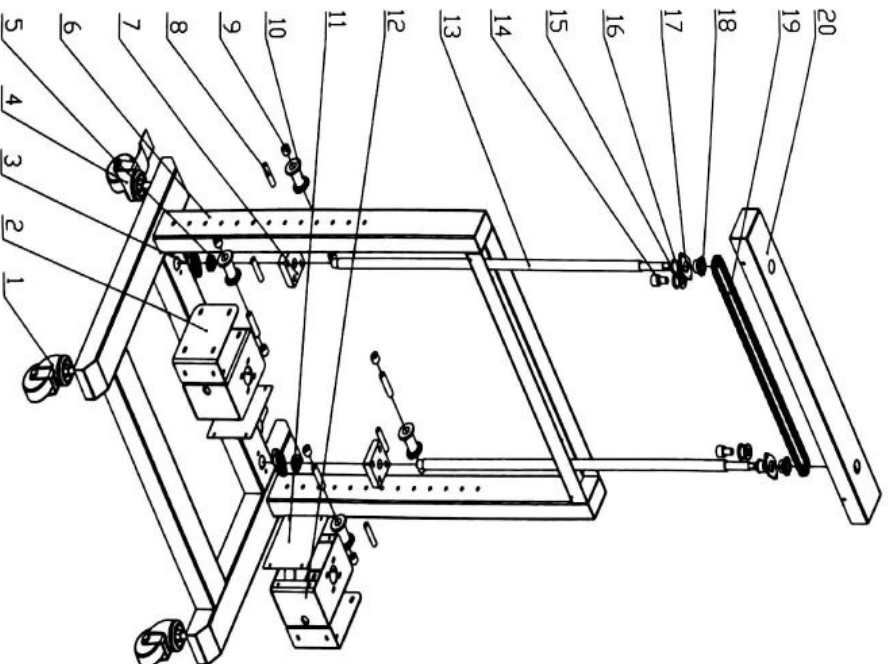

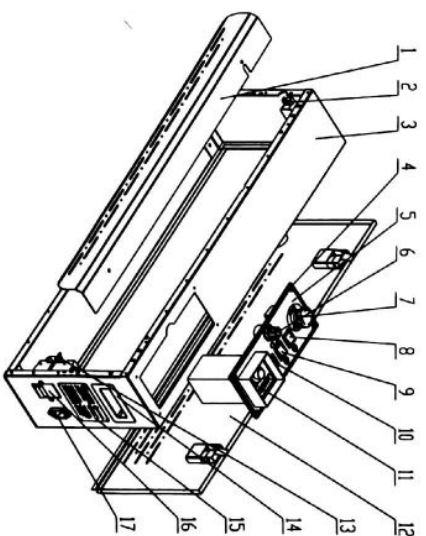

NO.	Parts Name	Qty	Specification	Remark
1	Foot wheel (without brake)	2	3"xM12	
2	Lifting nut fixing seat (left)	1		
3	Plane bearing seat	2		
4	Castors (with brakes)	2	3"xM12	
5	Thrust ball bearing	2	51103	
6	Bottom bracket (left)	1		
7	Lifting nut	2		
8	Strengthen shaft	4		
9	Roller copper sleeve	8		
9	Lift guide wheel spindle	4		
10	Position wheel	4		
11	blanking plate	2		
12	Lifting nut holder (right)	1		
13	lifting screw rod	2		
14	Chain tension wheel spindle	2		
15	Chain tensioner	2		
16	Bearing housing shaft sleeve	2		
17	Bearing block	2		
18	Chain wheel	2		
19	Chain	1	06B.122	
20	Top seal plate	1		

NO.	Parts Name	Qty	Specification	Remark
1	Cover	1		
2	Pull gloves lock block	4		
3	Frame	1		
4	Control Panel	1		
5	Control panel adhesive	1		
6	Speed adjusting knob	1		
7	Emergency switch	1	φ22	
8	Springboard switch (red)	1		
9	Springboard switch (yellow)	1		
10	Springboard switch (green)	1		
11	Temperature Controller	1		
12	Back door	1		
13	Card slot	1		
14	Handle gloves	2		
15	Name plate	1		
16	POWER	1	DZ47-63-2P	
17	Power socket	1		

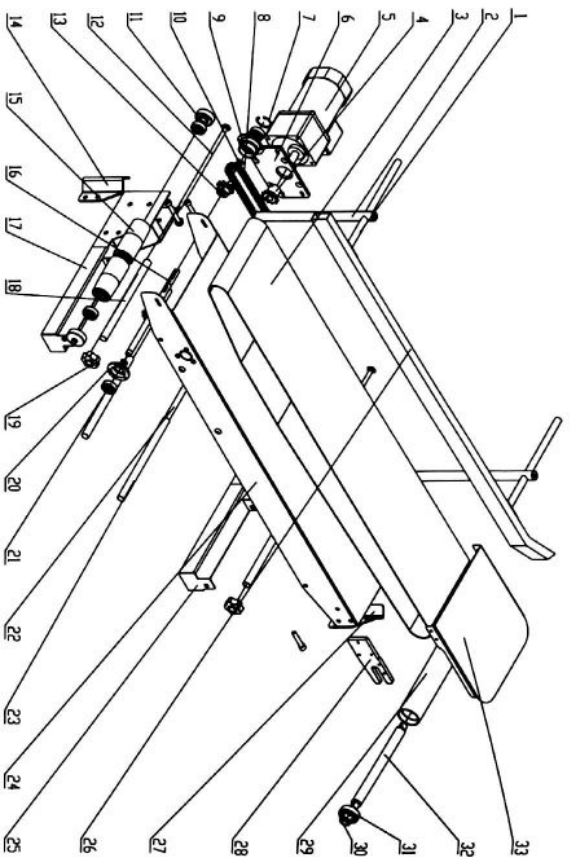

NO.	Parts Name	Qty	Specification	Remark
1	regulating stem weld	2		
2	Clamping rod	2	A3	
3	conveyor belt	1	PVC, perimeter=2145mm	
	Motor sprocket	1		
5	Motor	1	5IK120GU-CF+5GU-20K	
6	Motor mounting plate	1		
7	Spring	1	Φ32	
8	Chain	1	06B	
9	Bearing block (large)	1		
10	Axis with the spring	2	n12	
11	Active roller cover	2		
12	Retainer bolt	2		

16

13	Drive sprocket	1		
14	Conveying bar compression plate(Left)	1		
15	Aluminium sprocket roller	1		
16	Drive sprocket	1		
17	Conveying platform bracket (left)	1		
18	Bolt drivepipe	2		
19	Handle	2		
20	Bearing	1		
21	Deep groove ball bearing	4	6201ZZ	
22	Bracing piece	2		
23	Tensioning wheel	2		
24	Transfer Belts	1		
25	Delivery platform bracket (right)	1		
26	Transportation stop lever	1		
27	Transportation pressing sheet (right)	1		
28	Roller seat	2		
29	Passive roller	1		
30	Circlips for shaft	2	n20	
31	Deep groove ball bearing	2	6004ZZ	
32	Pass driven roller shaft	1		
33	Transfer counter	1		

17



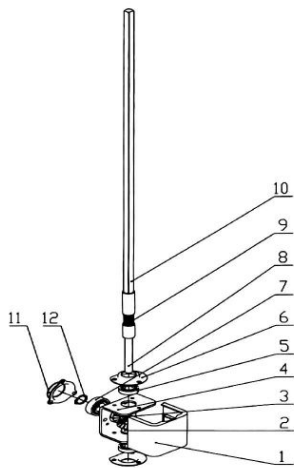

NO.	Parts Name	Qty	Specification	Remark
1	Bevel gear cover	1		
2	Bevel gear (horizontal)	1		
3	Bevel gear (horizontal)	1		
4	Bevel gear seat	1		
5	Deep groove ball bearing	2	6000	
6	Bearing	2		
7	Deep groove ball bearing	1	6003	
8	Bevel gear spindle	1		
9	Flexible shaft	1		
10	Bevel gear shaft	1		
11	The bottom bearing	1		
12	Circlip for shaft	1	φ17	

18

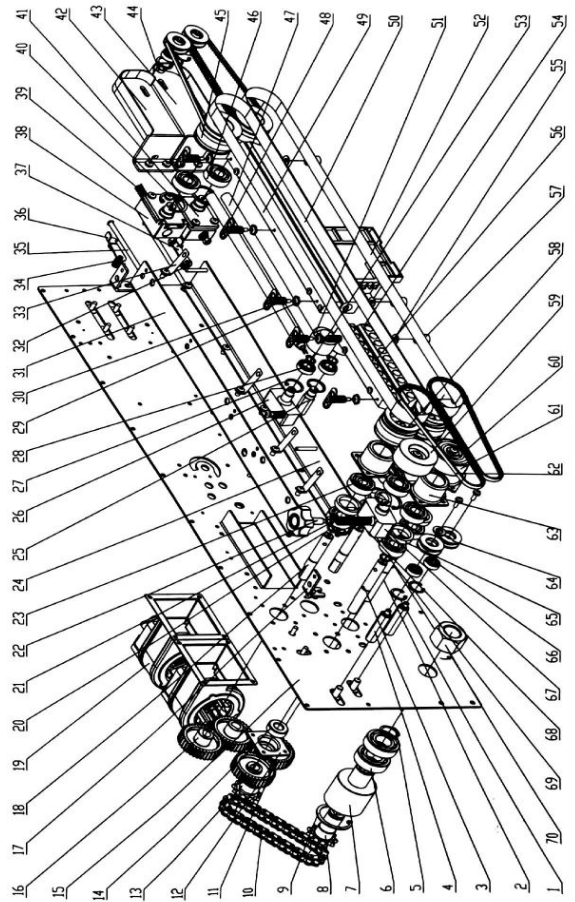

19



NO.	Parts Name	Qty	Specification	Remark
1	Circlip Hole	4	Φ19	
2	Dynamic spindle	1		
3	Rubber wheel spindle	1		
4	Driven wheel spindle	2		
5	Circlip Hole	1	Φ20	
6	Deep groove bearing	2	6004ZZ	
7	The fixed slide	1		
8	Main transition sprocket	1		
9	Circlip Hole	1	n42	
10	Chain	1	06B Chain,34 joint	
11	Driven wheel	1		
12	Rubber wheel support	1		
13	Gear connection sprocke	1		
14	Axis Guide	1		
15	Plate	1		
16	Driven gear	3		
17	Cover bracket	2		
18	Driving wheel spindle	2		
19	Fan	2		
20	Circlip Hole	1	n12	
21	Print wheel bearing	1		
22	Handle	1	M8X40	
23	Elastic split pin	3	Φ4X9	
24	Hot holder (lower)	1		
25	Double bearing mandrel	1		
26	Double bearing adjustment seat	1		
27	Circlips for shaft	2	n22	
28	Deep groove ball bearing	2	61900ZZ	
29	Spring seat	5		

20

30	Regulation spring	7		
31	Heating bracket (upper)	1		
32	Torsional spring	1		
33	Leaf spring	4		
34	Torsional spring	1		
35	Spring adjusting screw	2		
36	Hook	1		
37	Hook	1		
38	Upper passive wheel seat	1		
39	Passive wheel seat spring	2		
40	Circlip For Hole	3	Φ32	
41	Down passive wheel seat	1		
42	Front guide wheel support (upper)	1		
43	Front guide wheel support (down)	1		
44	Feeding guide wheel spacer	2		
45	Driven wheel	2		
46	Deep groove ball bearing	11	6201ZZ	
47	Heating tube	2	220V, 550W	
48	Ascension piece	5		
49	Heating block(up)	1		
50	Heating block(down)	1		
51	Roller shell	2		
52	Dealing belt	2		
53	Circlip for shaft	2	n10	
54	Cooling block (lower)	1		
55	Heat filter	4		
56	Cooling block (upper)	1		
57	Brace	4		
58	Driven wheel	2		

21



59	Print wheel	1		
60	Rubber wheel end cover	1		
61	Rubber wheel	1		
62	Gear belt	4	S410	
63	Driven bearing	4		
64	Driven wheel	4		
65	Bearing cover	4		
66	Deep groove bearing	4	626ZZ	
67	Embossing wheel adjust seat.	1		
68	Embossing wheel seat spring	1		
69	Circlips for shaft	3	n12	
70	Hex nut	1	M24	

2. FRD-1200V Parts Exploded Views & Names

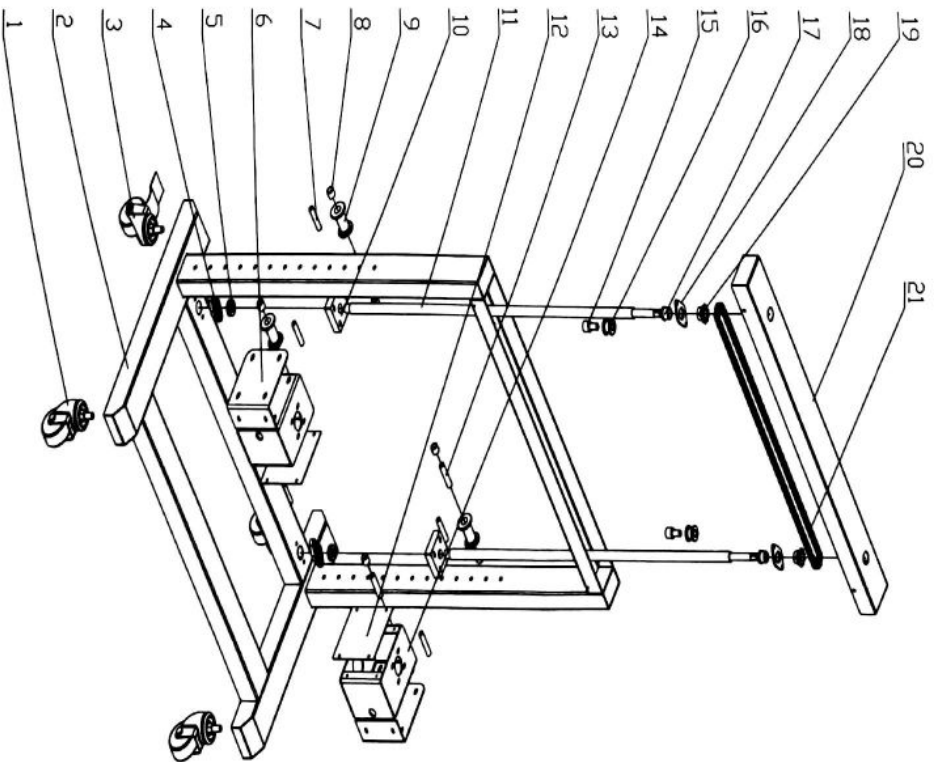

NO.	Parts Name	Qty	Specification	Remark
1	Casters (without brakes)	2	3*M12	
2	Bottom bracket (left)	1		
3	Casters (with brakes)	2	3*M12	
4	Plane bearing seat	2		
5	Thrust ball bearing	2	S1103	
6	Lifting nut fixing seat (left)	1		
7	Strengthen shaft	4		
8	Roller copper sleeve	8		
9	Locate the press pulley	4		
10	Lifting nut	2		
11	Lifting screw rod	2		
12	Shrouding	2		
13	Lift guide wheel spindle	4		
14	Lifting nut holder (right)	1		
15	Chain tension wheel spindle	2		
16	Chain tensioner	2		
17	Bearing housing shaft sleeve	2		
18	Bearing	2		
19	Chain	2		
20	On the seal plate	1		
21	Chain	1	06B,148 batch	

24

NO.	Parts Name	Qty	Specification	Remark
1	Back door	1		
2	Pull gloves lock block	4		
3	Frame	1		
4	Springboard switch (red)	1		
5	Emergency Switch	1	φ22	
6	Control panel adhesive	1		
8	Speed control knob	3	φ26	
9	The springboard switch (green)	1		
10	The springboard switch (yellow)	2		
11	Temperature Controller	1		
12	Control Panel	1		
13	Bolt M2x5	4	M2x5	
14	Handle cover	2		
15	Name brand	1		
16	Main switch	1	DZ47-63-2P	
17	Electric socket	1		

25

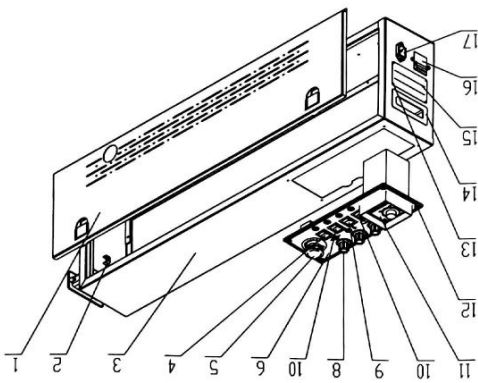

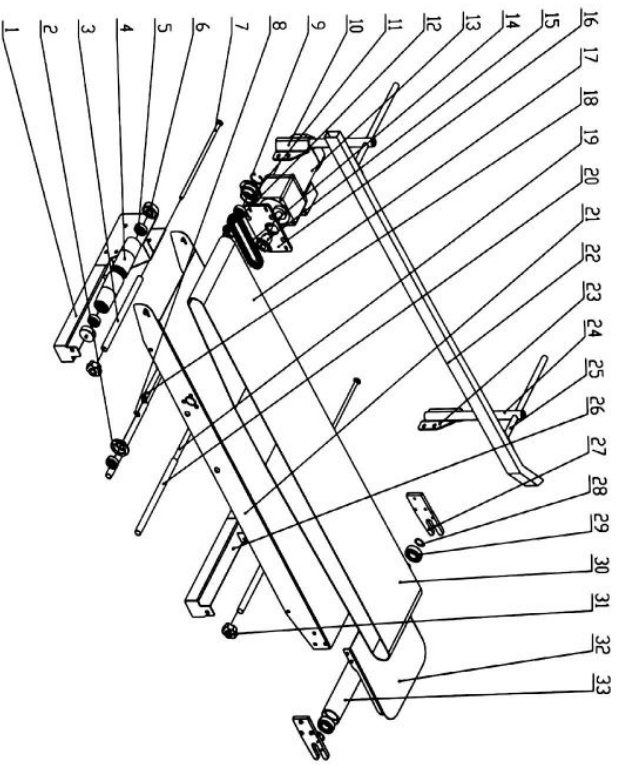

NO.	Parts Name	Qty	Specification	Remark
1	Conveying platform bracket (left)	1		
2	Bearing seat	1		
3	Screw tighten casing	2		
4	Aluminium sprocket roller	1		
5	Deep groove ball bearing	4	6201ZZ	
6	Active roller cover	2		
7	Adjust seat lock screw	2		
8	Axis spring	2	n12	
9	Hole spring	1	Φ32	
10	Conveyor stop bar compression plate (left)	1		

11	Bearing block (large)	1		
12	Drive chain	1		
13	Motor	1	5IK120GU-CF+5GU-20K	中大
14	Chain	1	06B chain ,34 batch	
15	Motor sprocket	1		
16	Motor mounting plate	1		
17	conveyor belt	1	PVC, = perimeter 2400mm	
18	Drive sprocket	1		
19	Bracing piece	2		
20	Stretching wheel	2		
21	Transfer Belts	1		
22	Transportation stop lever	1		
23	Transmission lever damp (right)	1		
24	Clamping rod	2		
25	Lever adjustment rod welding	2		
26	Delivery platform bracket (right)	1		
27	Roller seat	2		
28	Circlip for shaft	2	n20	
29	Deep groove ball bearing	2	6004ZZ	
30	Passive drum spindle	1		
31	Handle	2	M8	
32	Transfer counter	1		
33	Passive roller	1		



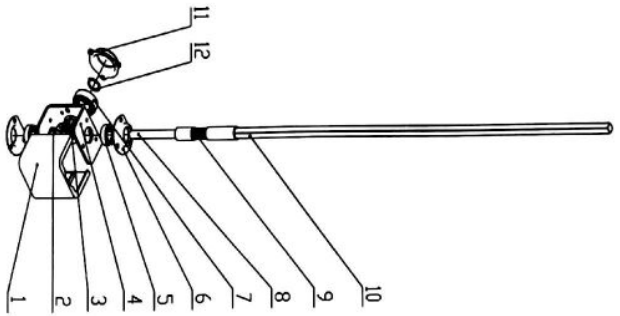

NO.	Parts Name	Qty	Specification	Remark
1	Bevel gear cover	1		
2	Bevel gear cover (horizontal)	1		
3	Bevel gear cover (vertical)	1		
4	Bevel gear seat	1		
5	Deep groove ball bearing	2	6000	
6	Tow sides bearing	2		
7	Deep groove ball bearing	1	6003	
8	Bevel gear spindle	1		
9	Flexible axle	1		
10	Bevel gear shaft	1		
11	Bottom bearing	1		
12	Circclips for shaft	1	Φ17	

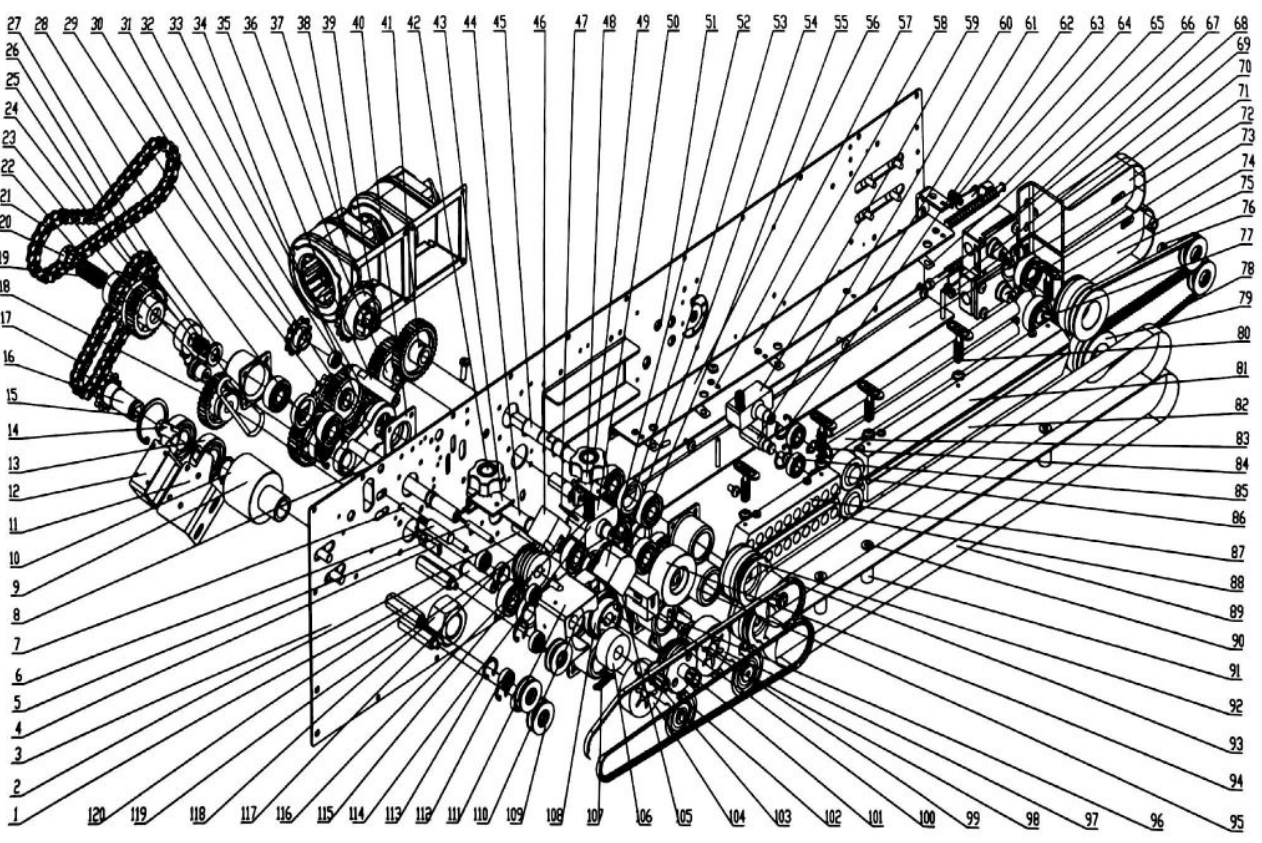

NO.	Parts Name	Qty	Specification	Remark
1	Guide wheel spindle	3		
2	Main drive spindle	1		
3	Panel	1		
4	Temperature sensor	1		
5	Heating tube in printing wheel	1	110V,60W	
6	Heating tube out printing wheel	1	110V,60W	
7	Ink wheel spindle	1	45	
8	Printing wheel shaft core	1		
9	The fixed slide	1		
10	Circlips for shaft	1	Φ20	
11	Electromagnet seat	1		
12	electromagnet	1		
13	Deep groove ball bearing	2	6004ZZ	
14	Electromagnet baffle	1		
15	Hole circlip	1	n42	
16	Main transition sprocket	1		
17	Chain	1	06B Chain,34batch	
18	Gear wheel	1		
19	Chain wheel spring.	1		
20	Rating nut	1		
21	Chain	1	06B,36 #	
22	Driving chain gear	1		
23	Pulley (ink wheel)	1		
24	Friction disc	1		
25	Friction wheel spring	1		
26	O ring belt	1	n4x53	
27	Friction disc washer	1		

28	Bersetzungsrud	1		
29	Gear connection sprocket	1		
30	Chain tension gear	1		
31	Plastic connection plate (top)	1		
32	Deep groove ball bearing	1	619-6	
33	Drive gear wheel	1		
34	Circlips for shaft	1	Φ22	
35	Chain adjustment shaft core	1		
36	Driven gear	2		
37	Drive sprocket	1		
38	Fan YJ48A1	2		
39	Circlips for shaft	8	n12	
40	Rubber wheel bearing	1	2.0/Q235	
41	Driven gear	1		
42	Handle	2	MBX40	
43	Regulating block	1		
44	Rubber wheel spindle	1		
45	Active sprocket shaft core	1		
46	Brush seat	1		
47	Brush plate	2		
48	Shield support	2		
49	Printing wheel plate	1		
50	Driving wheel spindle	1		
52	Brush seat cover	1		
53	Bearing seat cover	6		
54	Circlip For Hole	3	Φ32	
55	Deep groove ball bearing	17	6201ZZ	
59	Double bearing adjustment seat	1		



60	Double bearing mandrel	1		
61	Heating bracket	1		
62	Circlip For Hole	2	n22	
63	Torsional spring	1		
64	Hook	1		
65	Passive wheel seat spring	2		
66	Spring piece	4		
67	Upper passive wheel seat	1		
68	Spring adjusting screw	2		
69	Torsional spring	1		
70	Hook	1		
71	Front guide wheel support (upper)	1		
72	Heating bracket(down)	1		
73	Lower wheel seat	1		
74	Ascension piece	5		
75	Guide wheel support (bottom)	1		
76	Feeding guide wheel spacer	2		
77	Spring seat	5		
78	Gear belt	2	S410	
79	Driven wheel	2		
80	Perm adjusts spring	6		
81	Heating block (upper)	1		
82	Heating block (lower)	1		
83	Heating tube	2	220V, 550W	
84	Circlips for shaft	2	n10	
85	Deep groove ball bearing	2	61900ZZ	
86	Roller shell	2		

87	Cooling block (upper)	1		
88	Cooling block (lower)	1		
89	Sealing belt	2	周长 1210x18	
90	Heat filter	4		
91	Brace	4		
92	Driving wheel	2		
93	Gear belt	2	S656	
94	Printing wheel	1		
95	Transmission bearing seat	6		
96	Elastic split pin	3	φ4X9	
97	Rubber wheel	1		
98	Rubber wheel cover	2		
99	Approach switch	1		
100	Printing wheel cover	1		
101	Printing knob	1		
102	Ink wheel seat cover	1		
103	Printing wheel seat	1		
104	Silica gel wheel	1		
105	Photosensitive switch block	1		
106	Printing wheel	1	1.5 Domestic ink roll	
107	Heating block tension spring	1		
108	Printing wheel seat	1		
109	Driven wheel	5		
110	Ink wheel card	1		
111	Ink heater	1		
112	Deep groove ball bearing	5	626ZZ	
113	Hole card spring	7	Φ19	
114	Embossing wheel adjust seat	1		



115	Conducting ring	1		
116	Embossed wheel seat spring	1		
117	Bearing inner ring	1		
118	Hexnut	1	M24	
119	Carbon rush	2		
120	Silica gel wheel spindle	1	45	

9. Trouble Shooting of Common Fault

Faults	Causes	trouble shooting
off tracking of sealing	Driving wheel and driven wheel are unparallel	adjust the two screw of driven wheel, until they are not off tracking
Sealing belts break easily	<ol style="list-style-type: none"> 1. Sealing belts is too tight 2. Sealing belts is off tracking 3. Sealing belts has folding mark 4. Sealing belts are adhered with film or other dirt 5. Sealing belts is easy to melt 	<ol style="list-style-type: none"> 1. Adjusting the longitudinal adjusting screw of driven wheel seat, making the sealing belt is not too tight, also cannot be too loose 2. Refer to above method 3. Adjust or change, the sealing belts cannot have folding mark. 4. Clear away the adhesive materials and dirt on the surface of sealing belts in time 5. Adjust the distance between the heating blocks, or it caused by high temperature, adjust into suitable temperature.
embossing is not clear	<ol style="list-style-type: none"> 1. Embossing wheel has worn already 2. Embossing wheel seat pressure spring is not impacted 	<ol style="list-style-type: none"> 1. Change embossing wheel 2. Adjust the embossing wheel seat pressure spring
Sealing belts have resistance during transporting	The distance between heating blocks or cooling blocks are too small, friction is too big	Adjust the gap between heating blocks or heating blocks into suitable space. Normally the gap between the two sealing belts is about one layer thickness of the bag; this can ensure the sealing fastness and clear embossing, and will not make the sealing parts extend too long.
Plastic bag has block or bend over phenomenon when it runs into middle clamping wheel or embossing wheel	middle clamping wheel or embossing wheel pressed too tight	<ol style="list-style-type: none"> 1. Adjust the middle clamping wheel or embossing wheel into suitable pressure, make the gap between the two sealing belts is about one layer thickness of the bag; this can ensure the sealing fastness and clear embossing, and will not make the sealing parts extend too long. 2. After adjust the gap, adjust limit screw



Off tracking of conveyor belts	Driving roller shaft and driven roller shaft are not parallel	Adjust the driven roller shaft two conveyor tensioning adjustable knobs of conveyor table, to ensure the two shafts parallel, at the same time to make sure the conveyor tensioning is not too loose or tight.
Conveyor belt and sealing belt out of sync	Conveyor is not tensioning	1. Properly tension driving roller shaft and intermediate shaft conveyor belt, to make it entirely touch with idler wheel 2. Properly tighten conveyor belt

10.Maintenance

1. Keep the machine body clean and tidy, electrical parts should keep dry, ventilation
2. Before repairing the machine, must turn off the power. When start to repair, it should be repaired by professional or informed our factory for help.
3. This machine has one year warranty, namely the machine malfunctions due to quality problems within one year. Our Company will be free of charge for repair.
Or because of the improper operation, other natural disasters or force majeure cause faults, our company will charge you for the maintenance; replacement parts fee will charge according to its value.
4. Exceed warranty time, our company will keep on maintenance work, but it needs to charge you proper cost.
5. When the user repair by him, our company can sell parts.
6. Stop working for a long time, must turn off the power.
7. User should check all moving parts screw is loose or not before working every day.

Special note: Before debugging the machine, should not put any parts of your body in the removable parts of machine, for fear that scald or bruised!

Maintenance records and feedback

Thank you for purchasing the FR-1100V, FRD-1200V PE film vertical automatic sealing machine. Because of your right choice, you have a safe, practical and efficient sealing packing machine. Hope you become our long-term customers, any problems and your precious advice promptly tell us, we will timely reply you, thank you sincerely!

