

喷码机操作手册

Inkjet printer operation manual of

170PLUS 在线式喷码机

170plus online inkjet printer



请仔细阅读本操作手册，以便更好的发挥产品性能

Please read this operation manual to give better play to the
product performance

目录 catalogue

一、 产品介绍	Product introduction	4
二、 设备主菜单	Device main menu	5
三、 文件页面	File Page	5
四、 编辑界面	Add interface	6
4.1 文件	4.1 Text	7
4.2 新建	4.2 Date	7
4.3 保存	4.3 Picture	7
4.4 添加	4.4 Graphic code	8
4.5 编辑	4.5 Variable Graphics Code	9
4.6 旋转	4.6 counter	9
4.7 删除	4.7 Table file	9
4.8 打印	4.8 Create a new table	9
五、 打印页面	Edit page	10
六、 设置页面	Settings page	11
6.1 时间设置	8.1 Time setting	11
6.2 字体设置	6.2Font settings	12
6.3 打印设置	8.2 Print settings	12
6.4 喷头设置	8.3 Spray head setting	13
6.5 蓝牙连接	8.5 Data export	13
6.6 数据导出	8.6 Multilingual	13
6.7 多国语言	8.7Touchscreen calibration	14

6.8 触屏校准	8.7 Restore factory settings	14
6.9 恢复出厂	8.8 About	14
6.10 关于	8.9 System update	14
七、关于页面	About page	15
7.1 关于本机	7.1 About this machine	15
7.2 系统更新	7.2 System update	15
7.3 界面更新	7.3 Interface update	15
八、产品保修卡	Product Warranty Card	16
九、产品合格证	Product Qualification Certificate	17
十、视频演示	video demonstration	18
十一、正确安装墨盒	Install the cartridge correctly	19
十二、英文操作手册	English operation manual	20-25
十三、喷头尺寸详情	Nozzle size details	26
十四、DCJET 喷码机系列产品	DCJET products	27-28

**敬爱的客户您好：感谢您购买并使用我公司 PLUS 系统喷码机！
为了让您更好地了解、掌握使用这款机器请您仔细阅读说明书；**

**Dear customer: Thank you for purchasing and using our plus
system inkjet printer! In order to make you better understand and
master the use of this machine, please read the manual carefully;**

注：PLUS 系统喷码机编辑、操作系统大致相同。

**Note: the editing operating system of plus system inkjet
printer is roughly the same.**

一、产品介绍 Product introduction

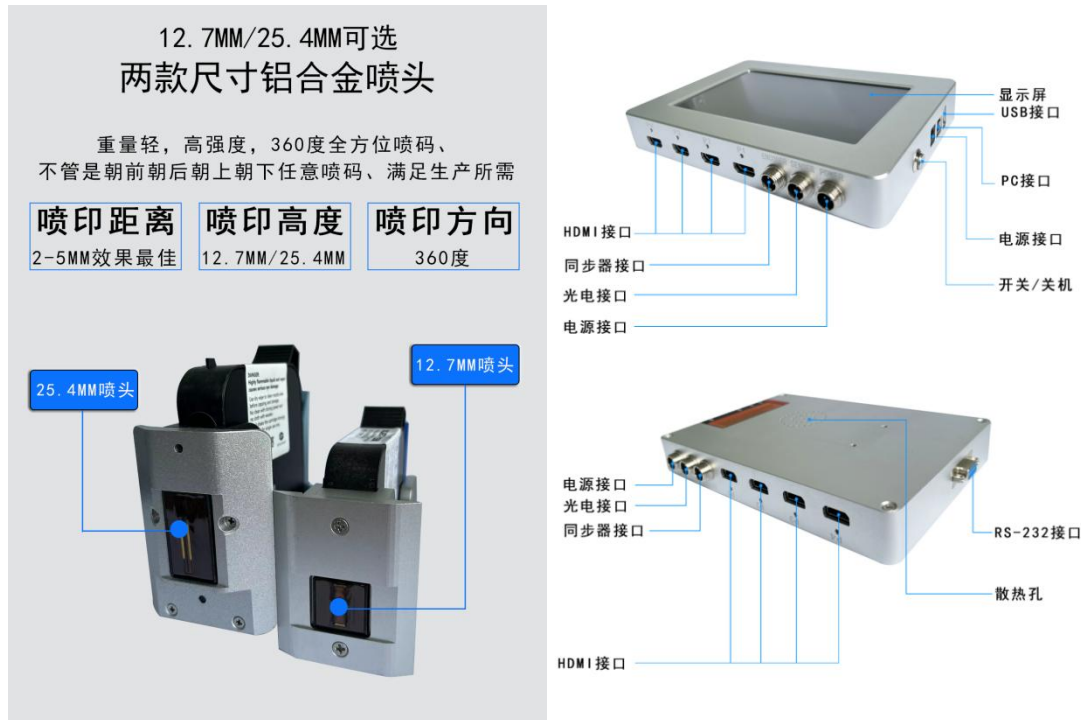

喷头特征: TIJ2.5 热发泡喷头, 全铝合金材质。

主机特征: 全铝合金机身, 7寸彩色触摸屏, 长 208mm 宽 135mm 高 30mm;

喷印方向: 360度全方位喷码、不管是朝前朝上朝下任意喷码、满足生产所需;

喷印字体: 点阵、实体、空心、圆点、方点、删除体等;

喷印图形: 可喷各种商标图案, 图形可通过 U 盘导入;

喷印精度: 300DPI、400DPI、600DPI (高清晰) 喷印行数: 1 至 15 行可调;

喷印高度: 2-100mm;

喷印条码: 二维码、条码、QR 码、DM 码等支持可变数据、一物一码;

喷印距离: 2mm~5mm 可保证最佳喷印质量 (喷头到被喷物体距离);

流水序号: 1-16 位可变顺序号; 电源参数: DC16.8V;

自动喷印: 日期、时间、批号、保质期班次和流水号等 (可随当天时间变动);

储存信息: 系统可储存 1000 以上海量信息 (可外插 U 盘将信息可保存随意调出);

信息长度: 每条信息喷印 2000 多个字体, 长度无限;

喷印速度: 最高可达 80 米/分钟; 可搭配各种包装机器使用;

使用油墨: 快干环保油墨、水性油墨、油性油墨、溶剂油墨、UV 墨;

墨水颜色: 黑色、红色、蓝色、黄色、绿色、白色、隐形等;

墨盒容量: 50 毫升, 一盒墨水可喷印 2 千万个字体 (2mm 字体);

外部接口: 电源接口、USB、PC、HDMI、光电接口、同步接口等;

语言选择: 中、英、阿、日、韩、等 28 国语言操作系统自带输入法;

工作环境: 温度 0-45 度 (20-30 度最佳), 湿度 40-60%RH;

操作系统: 全触摸屏 LINUX 操作系统, 四核处理器, 主频可达 1.4GHZ;

二、设备主菜单 Device main menu



1、主页面：显示基本操作及时间；

三、文件页面

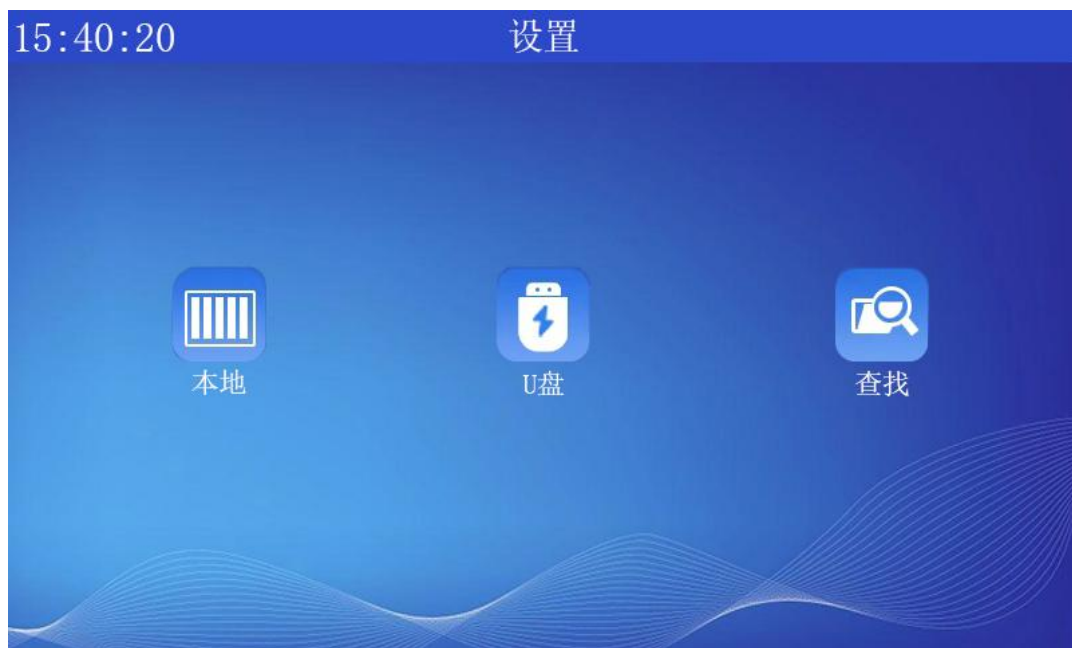

1、 本地 打开当前保存本地的文件；





2、 U盘 打开当前插上的 u 盘文件；



- 3、 查找保存在本地或插上 u 盘上的文件；

四、编辑页面



- 1、 **DCODE** 文件名：当前打印的文件名称；
- 2、 **11:59:25** 当前时间；
- 3、  信息尺寸长度；  信息尺寸高度；
- 4、  信息左右滚动条；
- 5、  文本内容上下左右微调 360 度旋转键；



6、 文件 可选择需要打印的信息（可从本地/U 盘上提取文件、查找保存在本地或插上 u 盘上的文件、新建文件、重命名文件、保存文件、将文件另存为）；

7、 新建 新建文件；

8、 保存 编辑的文本保存；



- 9、 添加需要编辑的打印内容：
- 9.1、 添加固定的文本信息（如汉字、数字、字母、符号等）；
- 9.2、 添加可变的当前日期和时间；
- 9.3、 添加 U 盘上的图片，图片格式必须是（BMP）单色位图；
- 9.4、 添加固定的条形码和固定的二维码（格式可选）；
- 9.5、 添加可变的条形码和可变的二维码；
- 9.6、 添加可变的计数器（位数可任意选择）；
- 9.7、 添加本地或 U 盘上的表格文本信息（通过电脑导入 U 盘）；
- 9.8、 可新建表格（行数、列数、行高、列宽、合并、拆分、线宽都可以设置）；
- 9.9、 添加机器上自带的常用图片，如®标；
- 9.10、 添加分段指一条信息上的内容与内容分开打印；



- 9、  **编辑** 选中文本上的内容即可自由编辑（字体、字间隔、字号、旋转、宽度、粗体、样式、斜体、外部数据都可设置）；

- 10、  **旋转** 选中文本上的内容即可进行旋转（最小值：0；最大值 360）；

- 11、  **删除** 选中文本上内容即可删除；



- 12、  **打印** 点击打印可直接开始喷印；  **返回主界面**；

五、打印页面



- 1、 打印编辑区，添加固定的文本信息

(如汉字、数字、字母、符号等)；

- 2、 暂停 打印后可随时暂停； 锁屏 整个界面锁屏，无法进行其他操作；

- 3、 显示打印条数和累计打印总数；

- 4、 可返回主界面；

六、设置页面



1、时间设置：可进行时间设置（年、月、日、时、分、秒都可以修改）；



2、字体设置：可对保存在本地或 U 盘的字体进行设置；



3、打印设置：选择按键音开关、打印开始音开关、打印结束音开关、同步字宽数值、同步方式（编码器、定时器选择）、打印次数、定时速度、重复打印、开始信号（手动开关、光电开关、距离开关、定时重喷可自由选择）、光电延迟、z 序打印；



4、喷头设置：选择墨盒个数、闪喷时间、镜像、调节水平间距垂直间距、喷头电压、墨盒类型、喷头脉宽、喷头交换、喷墨浓度、DPI 参数；



5、蓝牙连接：微信扫一扫连接设备；

6、数据导出：可将机器上的文体信息一键全部导出到 U 盘；



- 7、多国语言：支持多国语言操作系统选择（带输入法）；
- 8、触屏核准：当触屏不灵敏时可校准（也可开机时点击屏中间不动进入）；
- 9、恢复出厂：机器上的所有文本信息将会全部删除（慎重）；

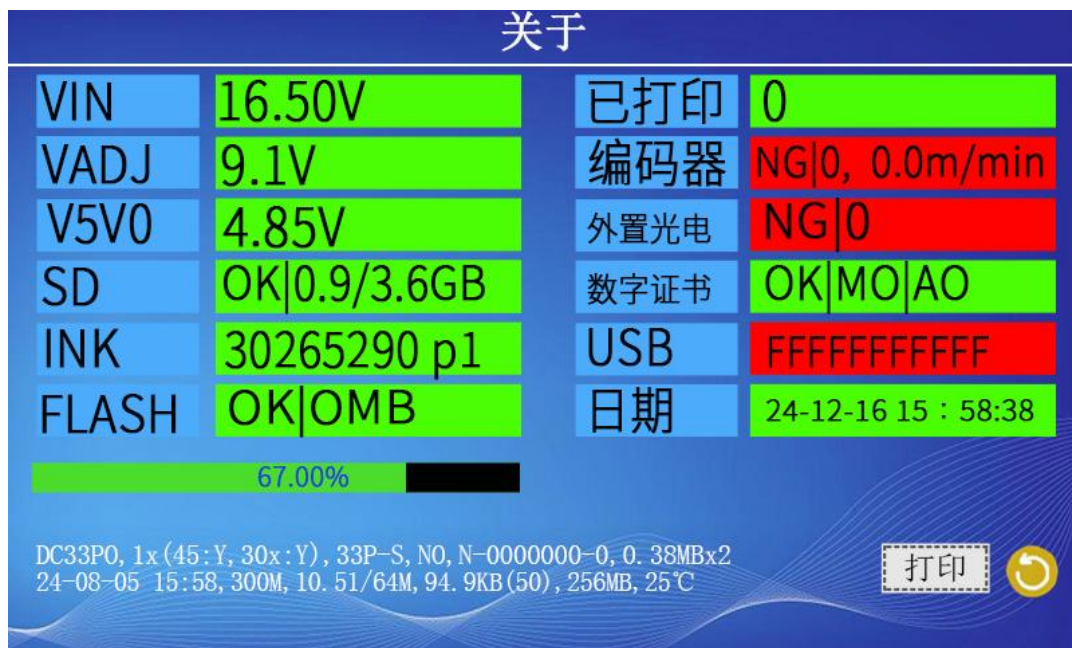

- 10、关于：可设置密码限制部分用户使用（慎重）；

七、关于页面



1、关于本机：观察机器上的所有电压及状况；

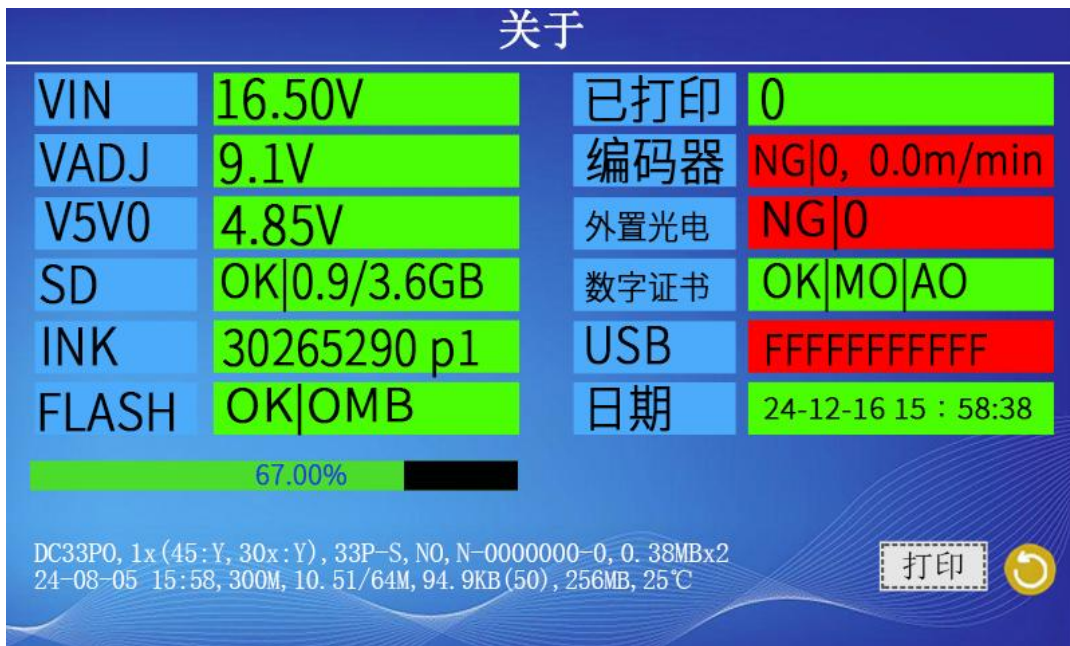

2、系统更新：可以用来更新最新的系统；

3、界面更新：厂家内部使用；

八、产品保修卡

Product Warranty Card

用户须知：

- 1、产品保修卡、保修服务的凭证；**
- 2、属于下列情况之一者，不在保修范围之内，维修酌情**

收费：

- (1) 保修期外**
 - (2) 用户自行对产品的工艺结构，电路进行修改，使用本厂以外耗材配件造成机器损坏的；**
 - (3) 产品与保修卡不符；**
 - (4) 易损、易耗品；**
 - (5) 因使用不当等人为因素或由于自然灾害等受到损坏的；**
- 3、保修期限为 1 年，自出厂日起，保修期内进行免费维修，且提供终身维修服务。**

条款最终解释权归我公司所有

九、产品合格证

Product Qualification Certificate

产品合格证

QUALIFIED CERTIFICATE

产品名称: 智能喷码机
PRODUCT NAME

规格型号: T170Plus
SPECIFICATIONS AND MODELS

生产日期: _____
DATE OF PRODUCTION

检验员: 0033
INSPECTOR

出品厂家: DCJET
MANUFACTURER

本产品经检验符合规定的
质量标准, 准予出厂

This product meets the requirements after inspection
The quality standard, allowed to leave the factory.



十、视频演示

video demonstration



墨盒安装操作方法
详细介绍操作方法



PLUS 手持式喷码机
操作方法



PLUS 手持式喷码机
触摸屏校准方法



多喷头手持式喷码机
操作方法及参数设置

十一、正确安装墨盒

Correct Installation of Cartridge

1、安装墨盒时，务必将机器关闭，以免对机器造成损害，墨盒 45 度，倾斜插入。

2、超过 20 分钟不使用机器，必须把墨盒从机器上取下，盖上专用的透明护夹夹好，避免长时间喷头暴露在空气中造成墨水干头。（务必保存好卡夹）

3、因为墨盒是快干性质，所以使用过程中出现少许拉丝，缺线现象，都是正常情况。

注意：墨盒属于耗材，使用即造成损耗，无法进行二次销售。拆封使用后不支持 7 天无理由退换货，敬请谅解。建议您下单前与我们进行联系，确定需求，以提供更好的服务。

Operational Manual

1、Product Introduction

Main features: Aluminum alloy body, color touch screen

Machine size: L 208mm x W 135mm x H30mm

Spray printing direction: 360 degree all-round inkjet printing, no matter it is forward, up or down angle arbitrary printing. It can meet all kinds of production needs

Spray printing font library: built in GB full font library, Pinyin input method, touch online editing, no need to connect computer, easy to operate

Ink jet printing font: high definition ink jet printing font dot matrix font, built-in a variety of Chinese and English fonts

Spray printing graphics: it can spray various trademark patterns, graphics can be imported through USB drive

Spray printing accuracy: 600dpi (high definition)

Spray printing line number: 1 to 15 lines adjustable

Printing height: 2 mm-100mm (different models, different maximum printing height)

Spray printing code: bar code, two-dimensional bar code, variable two-dimensional code, one thing one code

Spray printing distance: 2mm ~ 10mm (distance from the nozzle to the object to be sprayed) 2mm-5mm spray printing effect is the best

Serial number: 1-8 variable sequence number

Power parameter: dc16.8v,

Automatic spray printing: date, time, batch number, shift, serial number, etc. (it can change with the time of the day)

Storage information: the system can store more than 2000 large amounts of information (the information can be saved and transferred out by inserting a USB flash disk)

Message length: each message is printed with more than 2000 fonts, with unlimited length

Jet printing speed: up to 80 m / min

Use ink: quick drying environmental protection ink, water-based ink, oil-based ink

Ink color: black, red, blue, yellow, green, white, invisible quick drying

Ink cartridge capacity: 72ml, a box of ink can print 20 million characters (2mm)

External interface: USB, DB9, DB15, photoelectric interface, USB drive

Control panel: intelligent touch screen, support 18 languages with input method

Ambient temperature: 0 °C ~ 38 °C; humidity: 10% ~ 80%

Spray printing materials: carton, stone, MDF, keel, pipe, metal, plastic, wood, aluminum foil, etc

2、 Main Interface

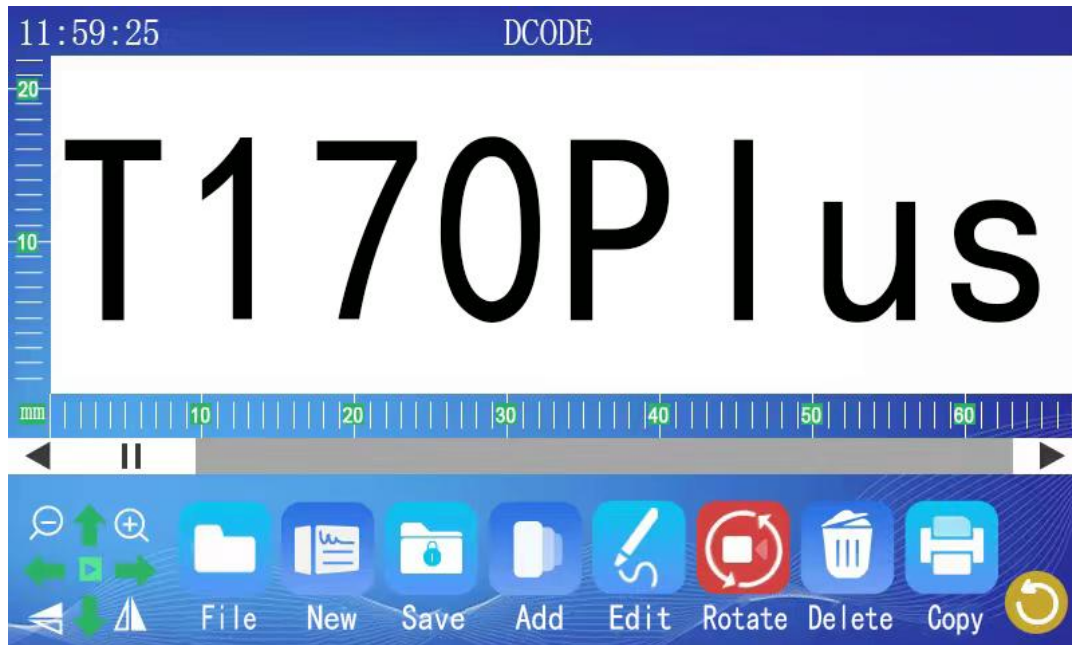

1、 **DCODE** File name: the name of the currently printed file



2、 Text content(up down left and right fine tuning key)



3. Choose the File



4. Create New File



5 Save the File



6. Add the file



7. Edit the file



8. Rotate the file













9. Delete the content you are selected



10. Copy the file











3.Add Interface



- 1、 Edit the Text
- 2、 Edit the date
- 3、 Put the photo from USB disk, the picture format is BMP Monochrome
- 4、 Edit the bar code
- 5、 Edit the variable Bar code and QR code
- 6、 Edit the batch number
- 7、 Import the Excel file
- 8、 creat a new table
- 9、 Edit the normal symbol
- 10、 Adding segments means that the content on a piece of information is printed separately from the content











4. Edit Text Page



- 1、 Text : Number and symbol switch button;
- 2、 Font: Support external fonts on USB disk
- 3、 Font Size: the more bigger number,the more bigger text;
- 4、 Width: Text the width;
- 5、 Font Style : Divided into entity, circle dot matrix, square dot matrix, delete body
- 6、 Word spacing: The space between words can be adjusted;
- 7、 Rotate: Text content can be rotated 360 degrees;
- 8、  Bold、 Italics;
- 9、  Confirm the message you edit, then back

5.Setting Page



- 1、 select the current system time setting
- 2、 set the fonts saved in the local or USB drive.
- 3、 select print direction, control mode, information width, etc
- 4、 select nozzle voltage, ink concentration, ink cartridge type, DPI selection
- 5、 WeChat scan to connect devices
- 6、 all the stylistic information on the machine can be exported to the USB disk with one key
- 7、 support multi language operating system selection (with input method)
- 8、 When the touch screen is not sensitive, it can be calibrated (you can also click the middle of the screen at startup to enter).
- 9、 all text information on the machine will be deleted (caution)
- 10、 observe all voltages and conditions on the machine

Operation Video

Check Our YouTube channel

<https://www.youtube.com/channel/UC-egb6nAQm8quiSqOut6SDA/playlists>

Correct Installation of Cartridge

1、 When installing cartridges, please be sure to shut down the machine so as not to cause damage to the machine. The cartridge is 45 degree inserted obliquely.

2、 If you do not use the machine for more than 20 minutes, you must remove the cartridge from the machine, cover the cartridge with a special transparent clamp, and avoid the ink drying caused by long exposure of the sprinkler to the air. (Make sure you keep your cartridge clip)

3、 Because the cartridge is fast-drying, a little wire drawing and line missing are normal in the use process.

Note: Ink cartridge belongs to consumables, which can not be sold twice. Please understand that there is no reason to return or exchange goods for 7 days after the use of the unsealing. It is suggested that you contact us before placing an order to determine the demand for better service.

喷头尺寸详情 Nozzle size details

半寸单喷头

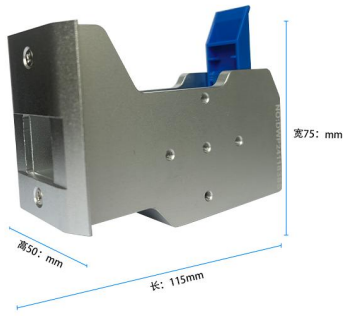

一寸单喷头

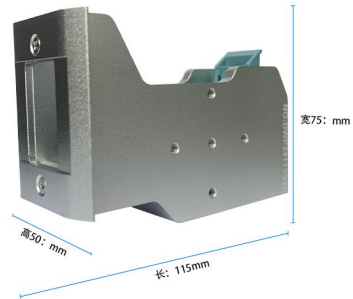

半寸双喷头

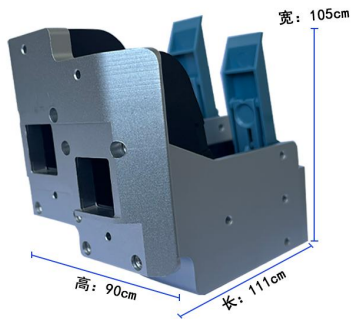

一寸双喷头

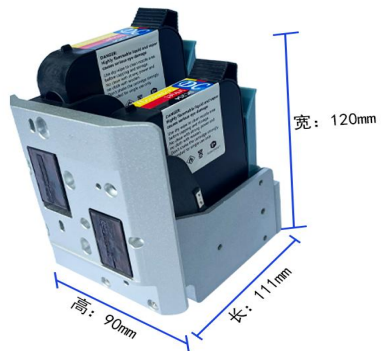

半寸三喷头

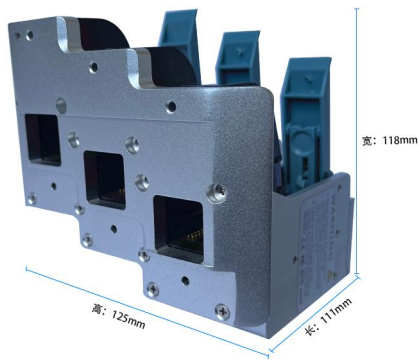

一寸三喷头

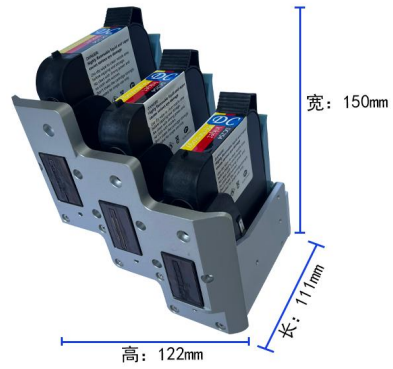

一寸四喷头

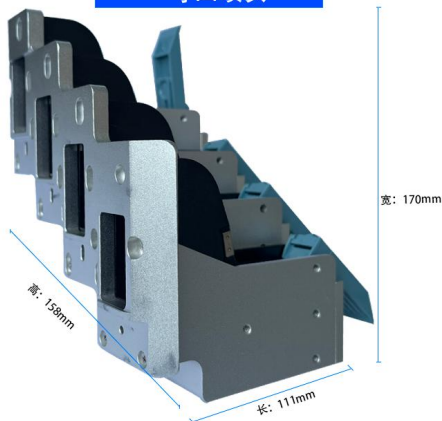

一寸六喷头

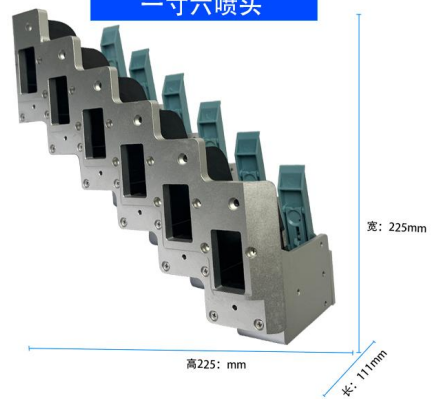

DCJET®
德创标识

专业喷码标识设备制造商
Professional inkjet coding and marking equipment manufacturer

迷你手持机



DC11-Plus



DC11-Plus



DC98-Plus



DC11-Pro

手持式喷码机



1780-Plus



1790-Plus



1790-Plus



1730-Pro

手持式喷码机



1750-Plus



1755-Plus



1760-Plus



530Plus半寸

手持式喷码机



530Plus一寸



530Plus双头



630Plus



730Plus

手持式喷码机



1760管材专用



530管材专用



1760板材专用



630板材专用

DCJET®
德创标识

专业喷码标识设备制造商
Professional inkjet coding and marking equipment manufacturer

在线式喷码机



T130Plus



T150Plus



T170Plus



T180Plus

在线式喷码机



T190Plus



DW-MiNi



DW-Pro



DW-Max

小字符喷码机



DC1820



DC1920

UV喷码机



DC-G50

墨盒



1755K



1730M



1704K

墨盒



G1309S



W6900K



M8700K