

**DY-8**

**COLOR RIBBON HOT PRINTING MACHINE**

**OPERATION INSTRUCTIONS**

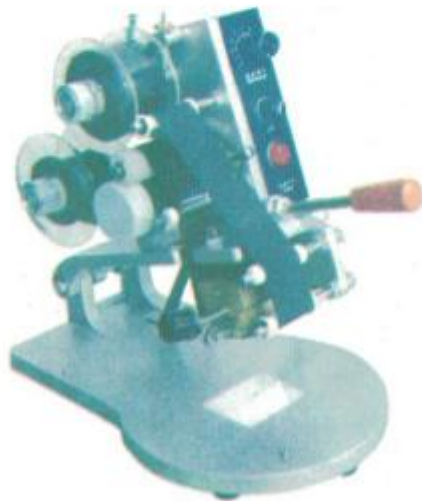

### **1.Usage**

The machine is suitable for all kinds of packaging materials such as plastic bag, aluminum foil, paper bag, leather etc. and print the color English words. It can be applicable for foodstuffs, drink, medicine and print producing date, expiry date, lot number, weight and price. The machine operates simply, change words convenient, clean and easily maintain.

### **2.Specification**

**Wording Model:by hand**

**The size of words: One line: 2.5×3.5,Max 12words**

**Double lines:2.5×3.5,Max 24words**

**Three lines:2.5×3.5,Max 36words**

**Ribbon:30mm**

**Work temperature:150~200℃**

**Heating power:40W**

**Voltage:220V/50HZ**

**Weight:2kg**

### **3.Operation process**

According picture 1 to install the ribbon, and then turn on the power. it should adjust the temperature if the materials change (the knob turn direct will make the temperature higher, turn reverse will make the temperature lower). When warm-up for 5 minutes, then press handgrip to print, if not satisfied with the effect, you can adjust the temperature to print until the font clear.

---

#### 4. Notice

- 1) Keep the print head clean to ensure the print font clear.
- 2) If the mandril nut loose, you must tight it up, and adjust the two adjusting bolts. Remember often lubricate the activity parts if Possible.

#### 5. Spare parts

- 1) Open spanner 5.5-7mm 8-10mm each one set
- 2) In-line screwdriver, cross-line screwdriver each one set
- 3) Color ribbon one roll
- 4) Alloy print head one box

We also supply the spare parts such as color ribbon, print head etc.

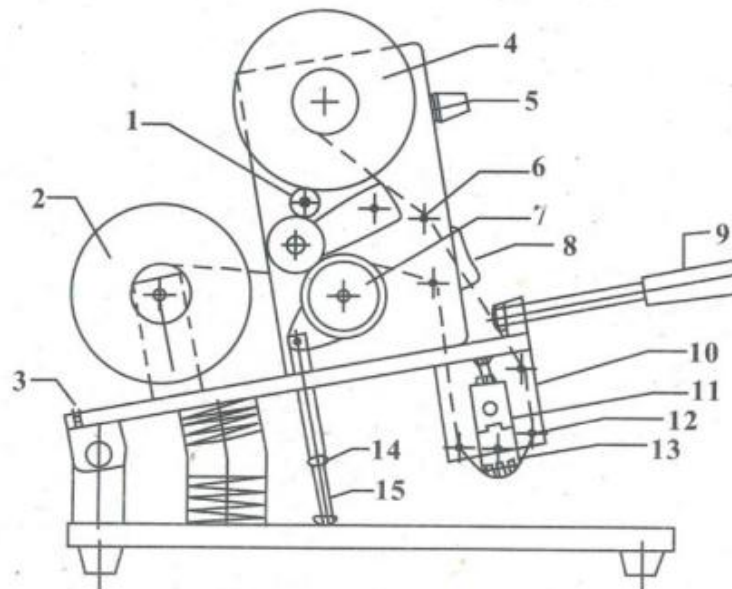

1. guid pulley
  2. take-up spool
  3. elevation adjust
  4. ribbon spool
  5. temperature controller
  6. guide tape rod
  7. tape load wheel
  8. powerswitch
  9. handgrip
  10. color ribbon
  11. heating pipe
  12. heating pipe
  13. pin head
  14. mandril nut
  15. adjusting bolt
-

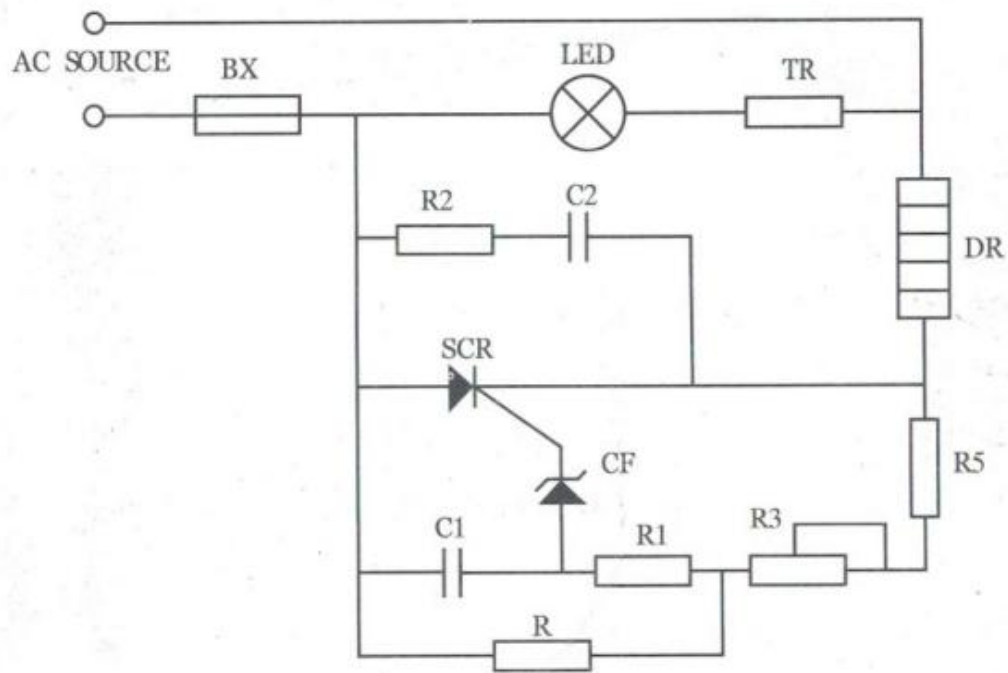

PICTURE 2